

# Communication Network

News for the people of FCC

ISSUE 30 2016

## FCC approves a 709 million euro capital increase



The Company will be recycling waste in Dallas for 15 years



FCC awarded Toyo (Colombia) tunnel project





## Cover



## The Group

FCC'S Board of Directors approves €709.5 million capital increase  
Pág 4



## Business

FCC opens the New Control Tower at Bogota Airport in the presence of the President of Colombia  
Pág 16

FCC refurbishes the Gracia Fortification in Elvas (Portugal)  
Pág 18

Vitoria installs containers adapted for the disabled  
Pág 19

## People

FCC participates in the program and scholarship award ceremony of Fundación Prevent  
Pág 24

Nine FCC Group women successfully complete the Career Development Program for Women with High Potential  
Pág 25

The Mersey Gateway team creates new children's playgrounds  
Pág 27

## Social responsibility

FCC takes part in United Nations Orange Day for the elimination of gender-based violence  
Pág 30

FCC Industrial Mexico: "16 days of activism against gender-based violence"  
Pág 32

Winners of the 12 best photographs of FCC Construcción projects  
Pág 39



## Well-being

The FCC Medio Ambiente Aragón-La Rioja Branch Office, open seminar for the families of FCC employees

Pág 40

12 months, 12 causes for one objective: road safety

Pág 44

Training plays a key role in safety and health management

Pág 49

20th anniversary of the Prevention Law 31/1995

Pág 51



## Knowledge

Matinsa develops an intelligent lighting system for tunnels

Pág 56



## The Place

Callao Port, Perú  
Enlargement of one of the largest ports in the Pacific  
Pág 62



## Communities

FCC to recycle Dallas waste for 15 years

Pág 68



# The Group

# FCC's

## Board of Directors approves €709.5 million capital increase

FCC Group's Board of Directors, in its meeting on 17 December, approved a capital increase for a total cash amount of approximately €709.518 million through the issuance and distribution of 118,253,127 new common shares for a unit price of 6 euros per share. FCC shareholders will hold preemptive rights to the new shares.

FCC core shareholders (Esther Koplowitz and Inversora Carso) have both informed the Board of Directors that they are committed to subscribing, directly or indirectly, the total number of shares that is proportional to them in the exercise of their preemptive rights. Inversora Carso has also affirmed its commitment to subscribe surplus shares in the event that, upon completion of the preferential subscription period and the additional allocation period, there are unsubscribed shares left over.

The capital increase was agreed upon within the framework of the authorisation granted during the General Shareholders' Meeting held on 25 June 2015. The primary aim is to reinforce the company's capital structure and reduce the level of FCC Group debt.

Chief Executive of the Group, Carlos M. Jarque, informed the Board that the funds ob-

tained through this process will be used to repurchase discounted debt resulting from the so-called Tranche B and to financially back the subsidiary Cementos Portland Valderrivas. The funds will also be used for general corporate purposes. In this regard, FCC aims to exercise its preferential subscription rights in the capital increase announced by Realía on 10 November.

The capital increase agreed upon by the highest governing body of FCC is subject to the double condition precedent of obtaining authorisation from its main financing bodies to use the funds from the increase and of their commitment to proceed to sell, with a discount of at least 15%, a minimum amount of debt arising from Tranche B of the financing agreement that entered into force on 26 June 2014.

“

Inversora Carso expressed its commitment to subscribe the surplus shares in the event that some shares remain upon completion of the process

”

“

The Group's core shareholders (Esther Koplowitz and Inversora Carso) have reported that they will, directly or indirectly, participate in the capital increase

”

“

Shareholders may subscribe the new shares at a price of 6 euros/share

”



# Christmas 2015 greetings

Dear staff,

We did not want these holidays to go by without expressing our warm greetings and our appreciation.

We are certain that will enter a new phase in the coming year, exciting and full of hope, in which we will continue to facilitate the lives of our co-citizens, improving and consolidating the quality of our services with a single objective: to build a better future for everyone.

With this spirit, we wish to wish all of you who day in and day out FCC possible, a very Merry Christmas and a 2016 full of good projects.

**Esther Alcocer Koplowitz**  
Chairman

**Carlos M. Jarque**  
Chief Executive Officer



En 100 años  
prestando servicios  
a los ciudadanos  
hemos visto cambiar  
muchas cosas,  
la primera de ellas  
al propio ciudadano.

En FCC diseñamos y construimos infraestructuras, recogemos, reciclamos y valorizamos residuos urbanos e industriales, limpiamos calles, cuidamos parques y jardines, mantenemos el mobiliario urbano y gestionamos el agua en 5.000 municipios de todo el mundo desde hace más de 100 años. Al principio éramos unos pocos preocupados porque millones de personas disfrutasen de un lugar mejor donde vivir. Hoy son esos millones de personas los primeros que se preocupan por crear un lugar mejor donde vivir.

Lo estamos haciendo juntos.

## Esther Alcocer Koplowitz in Bogota at the presentation of Fundación Consejo España-Colombia



The chairman of FCC, FCC, Esther Alcocer Koplowitz, was in Bogota for the presentation Fundación Consejo España-Colombia, an event presided by the chancellor of Colombia, Ángela Holguín, and the minister of Foreign Affairs and Cooperation of Spain, José Manuel García-Margallo.

foreign policy instrument that is based on public-private collaboration which will also contribute to deepen our bilateral relations and to encourage contacts”, Minister García-Margallo said.

Chancellor Holguín and Minister García-Margallo later welcomed the representatives of the companies that are members of Fundación Consejo España-Colombia, whose chairman is Esther Alcocer Koplowitz.

Fundación Consejo España-Colombia is a private non-profit organization which aims to strengthen bilateral relations in all possible aspects: economic, business, political, social and cultural.

“Thanks to Fundación Consejo España-Colombia, we were able to launch this unique



## FCC performs an evacuation drill at the Las Tablas headquarters

FCC performs an evacuation drill at the Las Tablas headquarters to confirm the correct functioning of the Self-Protection Plan, designed in accordance with applicable current law. The objective of the drill was to ensure the safety of all employees by being a step ahead of possible situations in an actual incident.

Carlos M. Jarque, CEO of FCC, took part in the drill, performed periodically every year, with the employees who work in the building. Members of the municipal police force of

Madrid were present during the entire evacuation drill to ensure safety, control traffic, and to confirm the coordination of the emergency teams during the drill, which was directed by the head of emergencies, the head of the self-protection plan, and the first responders, alarm, and evacuation teams.



See Link

To check all information on emergency situations go to One by clicking on link provided below:

 GLOBAL BUSINESS TRAVEL

La forma más fácil de solicitar tus viajes

Bienvenido a *Destiny* [entrar](#)

## New e-travel portal for the FCC Group

The FCC Group has been working with the agency American Express Global Business Travel since June 1. This collaboration includes the new e-travel portal: the DESTINY Portal.

The website will be of help in managing the travel plans of FCC Group personnel, facilitating the work of Travel Managers and the travellers themselves.

Among the many advantages, the portal will make it easier to organize, obtain approval, to check alternative travel plans immediately, and also offers the possibility of checking re-

quests and invoices. It will also house the profiles of passengers with their basic data, including seating preferences, reward cards, travel documents and other useful information.



Access



Access the Manuals of the Organizers, Travellers' and the Authorizers.



## Carlos M. Jarque meets with the FCC teams in Austria and in Barcelona

**The CEO met with Austria with the FCC International, Central and Eastern Europe Environment team and travelled to Barcelona to learn first-hand about the opinion of employees and managers.**

### **Austria**

Carlos M. Jarque, the CEO of FCC, visited the installations of FCC Environment Central and Eastern Europe (CEE) facilities in Austria where he met with the local teams of this subsidiary. Jarque was accompanied by Agustín García Gila, the chairman of FCC Medio Ambiente, and by Antonio Alfonso, manager of this subsidiary's international department. The CEO pointed out in his meetings with managers and employees of the subsidiary in Austria, the importance for the Group of the Environment and Water divisions.

The CEO referred to the quarterly earnings reported by the Group whose healthy balance sheet and improvement was driven by a 14.7% increase in its international activities where it recorded double-digit growth in all business areas. He mentioned that the subsidiary in Central and Eastern Europe contributed 12.7% of the earnings of the Environment Division and said that he was convinced that "there is still room for significant upside that can be achieved through productivity and by developing new projects".

Jarque encouraged the FCC Environment CEE's teams to "feed the strategic vision of the entire Group" as one of the priorities included in the list of challenges that had to be tackled immediately. These challenges also include the extension of concessions, technological innovation, the profitability of all projects, and being permanently aware of the changes in a sector that is constantly evolving.

As part of this list of challenges, Jarque referred to teamwork and the generation of synergies with the rest of the Group, the need to preserve and to encourage talent within the organization and the conjunction of the economic, financial, and social aspects of each of the Group's projects.

## Achieve better results

The Group's CEO expressed his conviction that the result of this teamwork would be enhanced earnings performance that would be reflected in the Group's balance sheet. To this end, he invited all to "work with enthusiasm and creativity".

Jarque, accompanied by Bjorn Mittendorfer, the senior executive at FCC Medio Ambiente CEE; visited the facilities at Zistersdorf (50 kilometres north of Vienna); a waste to energy facility which generates nearly 110,000 MW of electricity from non-hazardous urban and industrial waste.



## Barcelona

In early December, Carlos M. Jarque visited the various branch offices of FCC in Barcelona where he met with the Group's employees and managers to explain his strategy and to learn first-hand their opinion on the current projects in the different areas and to analyse the future of the Group in Catalonia.

During his stay in the city, he visited several installations in Balmes street as well the Archive and Documentation premises where a large part of the documents of the Citizen Services Group are stored. He also visited the Carriage Museum in the Vall d'Hebron district. The Group's CEO met with the ma-

nagers of the Construction, Environment and Water divisions who described the evolution of their respective business areas as well as the projects in which they are currently working for the future. Jarque also wanted to hear about the opinions and the concerns of the members of the workforce of the different departments with whom he conversed for a long time.



# *¿Te gusta cantar?*



## **FCC invites you to participate in the creation of a musical chorus**

FCC invites to participate with your colleagues in the creation of a musical chorus. If you like music, like to sing and do volunteer work, don't think twice. You can have a good time while you enjoy music at the facilities in the Las Tablas headquarters.

If you are interested, get in touch with Carlos Labajo Salazar and call him at 91 757 32 45 or send an e-mail to [clabajos@fcc.es](mailto:clabajos@fcc.es).

It is not necessary that you have knowledge of music; if you sing, play a musical instrument, or want to lead the group as its director, this is your chance to do it.



Remember that for each video you send, FCC will donate a book to the Red Cross. Thank you very much for your participation!



See Link

[www.fccjinglebells.com](http://www.fccjinglebells.com)

This  
Christmas  
will sound  
like a fairytale

## Christmas at FCC

During these holidays, FCC launched the campaign “Esta Navidad te va a sonar a cuento” a positive and participative initiative which was conducted throughout the entire Group worldwide.

The accent of this campaign was on all of those who are part of FCC. The Group’s employees in Spain and abroad were asked to donate their favourite children’s storybook to their local Red Cross and to participate in the Christmas greeting by putting music to the story and singing it as a Christmas carol.

Many decided to participate, alone or with their colleagues, to sing the Christmas carol, not only in Spain but also in other countries such as Panama, Costa Rica or Bulgaria, sending their videos via their cell phones to a specific WhatsApp number for this occasion.

The objective of this simple process was to facilitate the participation of all employees who lack a computer at their work place.

The videos that were sent were hosted at the [www.fccjinglebells.com](http://www.fccjinglebells.com) website where they received thousands of votes. The most popular ones were included as part of the Christmas greetings that FCC sends to its employees who were asked to share these with their contacts.

For each of the many people who decided to sing the Christmas carol for the holiday greeting, FCC added another storybook for the Red Cross. These, combined with the large number of books that had been dona-

ted by the Company’s employees, brought the total to X books worldwide.

In this way, all the employees who decided to participate, one way or the other, have contributed their grain of salt so that this Christmas had a happy ending.

The “Esta Navidad te va a sonar a cuento” initiative created a video teaser, a screen saver adapted to the occasion a website and a graphic campaign in order to reach as many people as possible.





## Thank-you note for our contribution to this initiative “1 millón de compromisos por el clima”

The Ministry of Agriculture, Food and the Environment and Fundación Ecología y Desarrollo (Ecodes) sent a thank-you note to the FCC Group for having contributed to the historical agreement at the Paris Climate Summit, whose aim was to prevent that the temperature in the world increases by more than two degrees by the end of the century.



### Thank-you note:

THANKS!

The Paris Climate Summit reached a historical agreement. It was not what many wanted, but it was much more than everyone was expecting. The agreement, as expressed by Ban Ki-Moon, paves the way to a low-carbon economy. All of the countries in the world will work towards the same goal: prevent temperatures from increasing more than 2 degrees and aiming for this increase to be no more than 1.5 degrees.

Many people were behind the agreement, clearly all the delegations who attended the summit. But also, in Paris, the absence of those who were not at the summit was felt strongly: entities and people who, thanks to their actions, have been behind the global #For the Climate movement. We include you in this group. Many, many thanks for having contributed as part of your responsibility to have made this agreement possible. Without your mobilisation, without the actions of thousands of entities and millions of people from around the world who are committed to the climate prior to the Paris Summit, the agreement that governments would have designed would have certainly been more lukewarm.

We gave a book with the names of the individuals and entities who have expressed their commitment to the ONE MILLION COMMITMENTS FOR THE CLIMATE to the Executive Secretary of the United Nations Framework Convention on Climate Change, Christiana Figueres, who thanked us very warmly and enthusiastically. We convey to you her appreciation. Your entity has contributed to lightening up a new epoch, that of the low-carbon economy. Thank you very much.

Now all countries, organizations and individuals must take coherent actions in line with the global objective of the agreement: ensure that the temperature of the planet does not increase by more than 1.5 degrees. Let us continue then to take actions #For the Climate.

Best regards,  
The #For the climate team



See PDF



**1 MILLÓN**  
DE COMPROMISOS  
*por el clima*



## FCC opens the New Control Tower at Bogotá Airport in the presence of the President of Colombia



For further information:

The President of the Republic of Colombia, Juan Manuel Santos, has opened and declared pre-operational the New Control Tower and the Management and Control Building of the Civil Aviation of El Dorado International Airport. The infrastructures were built by FCC, the Spanish environmental services, infrastructure and water group, in Bogotá, 15 kilometres to the west of Colombia's capital.

Also present at the event were the Minister of Transport, Natalia Abello, and the Director of Civil Aeronautics, Gustavo Lenis, representing the Government of Colombia along with, amongst others, Carlos M. Jarque, executive director and CEO of FCC, Vicente Mohedano, managing director of FCC Construcción, José María Torroja, director of the Latin America Area, Pedro Collado, director of the company in Colombia,

and Emilio Otermín, construction project manager.

After 40 months, an investment of over 50 million euros (155,000 million pesos) and a total surface area of 16,000 square metres, FCC has completed an infrastructure that will service the rise in air traffic volume at El Dorado airport. It is the busiest cargo airport in Latin America (648,000 tonnes per year) and the third busiest passenger airport (20.4 million per year). The new control tower, standing at around 90 metres tall, is now the tallest and best equipped tower in Latin America. The air traffic control systems have been developed to guarantee the best air navigation service in the region.

The control tower has been designed to meet the requirements for the airport's air traffic control service, primarily in critical areas. This will reinforce the safety, regulations and alertness demanded by the air-

space users. It will also guarantee maximum operational capacity of the airfield and will update technology to be at the global forefront.

This new tower will comprise two cabins, one for air traffic control and another for controlling the SDPM platform, which guarantee 360-degree visibility of the airport and line of sight to the heads of each runway.

With this project, one of the most important aviation infrastructure projects awarded by the Colombian Civil Aviation Authority, and executed by FCC, the country will have a modern facility in line with future needs and challenges to provide air traffic services and air navigation in the American continent.



# FCC to execute the Toyo tunnel project in Colombia for 392 million euros

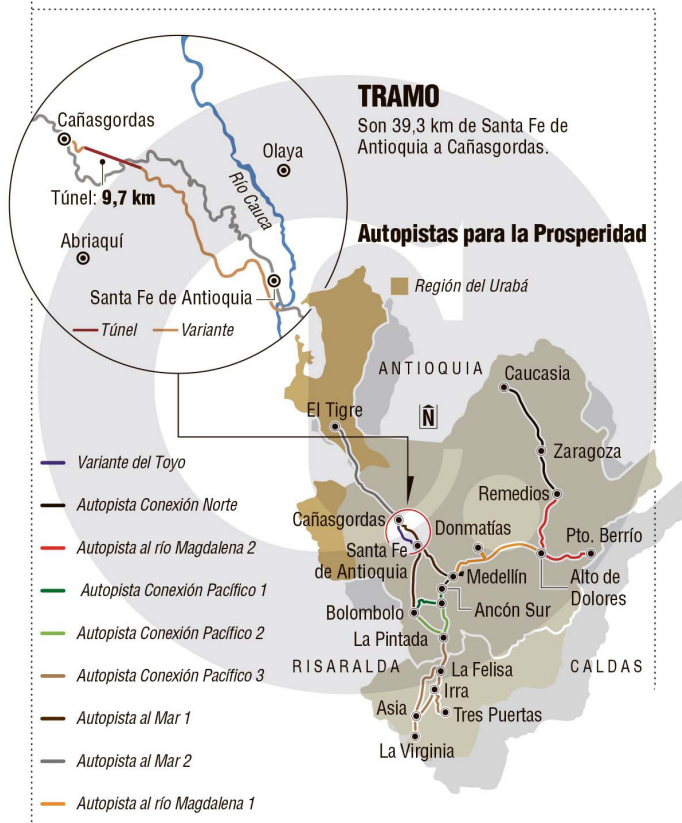

enlarge image

FCC has been awarded the contract for the project consisting of the design, construction, operation and maintenance of the Toyo tunnel in the Urabá Port (around 80 kilometres from Medellín) with a budget of 392 million euros (1.1 trillion Colombian pesos). The Government of Antioquia awarded the project to a consortium led by the Citizen Services Group (with a 40% share) and a group of local businesspeople (with the remaining 60%).

The project is to be fully executed over 10 years, six of which will be dedicated to the construction phase and two and a half to operation and maintenance. The rest of the time will be spent on the design phase and any necessary pre-construction work.

Other large international infrastructure groups also took part in the tender process. It is estimated that the Toyo tunnel works will directly create one thousand jobs.

### Between Giraldo and Cañasgordas

The project, located between the municipalities of Giraldo and Cañasgordas, around 500 kilometres north-west of Bogotá, consists of building a completely new road section, 40.84 kilometres long in two directions with one lane in each, although there will also be a dual carriageway section with two lanes in each direction. This section will pass through the mountains of western Antioquia, in an area that is difficult to access. The works will substantially improve the connection between Medellín and the region of Urabá, given that the journey between the capital of Antioquia and Urabá will be cut from the six hours it currently takes to three and a half when using private vehicles, once the whole Toyo tunnel project is up and running. For lorries, the journey will take around four hours. The highways Mar 1 and Mar 2, forming part of the Autopistas de la Prosperidad programme, amongst other infrastructure in the region, will also contribute to this shorter journey time.

The complete project also includes 12.3 kilometres of tunnels, 9.8 of which will make up the Toyo tunnel, added to the new road leading to Urabá. Once complete, this infrastructure will be the longest of its kind in Colombia.

The contract contemplates the design, construction, operation and maintenance of the works over a period of 10 years.

Spanning over 10 kilometres, the tunnel will be the longest one in Colombia.

The project is expected to create more than 1,000 direct jobs.

# FCC refurbishes the Gracia Fortification in Elvas (Portugal)



Classified as a National Monument and a World Heritage Site by UNESCO, the fortification opens to the public after one year of refurbishment work.

FCC completed the refurbishment of the Gracia Fortification in the Portuguese city of Elvas in the Portoalegre district; 195 km from Lisbon and less than 20 km from Badajoz. Anibal Cavaco Silva, the president of the Republic of Portugal, inaugurated the project. Attending the ceremony on behalf of FCC Construcción were Antonio Pérez Gil, representative of the Centre and Portugal branch office, and Antonio Ribeiro Mendes, the country manager in Portugal.

Also known as the Conde de Lippe Fortification, it has been classified as a National Monument and a UNESCO World Heritage since 2012. Ramalho Rosa Cobetar, the Portuguese subsidiary of FCC Construcción, was in charge of the refurbishment of this architectural complex of a military nature.

The aim of the project was the recovery and conservation of the structure of the refurbishment of the fortification which occupies a 12 hectare area. The investment required was 56.1 million euros, 4.7 million of which was a subsidy from the European Union and

the remaining sum contributed by the Municipal Chamber.

The work consisted mainly of recovering the walls, cleaning the tapestries, and repairing the damage caused by neglect. The military compound has been adapted to house cultural events and is open to the public. A museum program was prepared for the purpose of recovering its history.

## FCC's experience in refurbishment

FCC Construcción has broad experience in the refurbishment of historic buildings, including the General Archive of Simancas in Valladolid, the Fuensalida Palace in Toledo, and the Casón del Buen Retiro and the Prado Museum in Madrid.

## One of the most important fortifications in the world

The Gracia Fortification is considered one of the most important one in the world. In 1980 it ceased to be military building and remained neglected and abandoned since 1992.

The site consists of three defensive lines: the first line is a polygonal structure that creates a star-shaped fortress. The second line consists of a fortified bastion, and the third line includes a central fortress, an octagonal tower with vaulted ceilings which houses the governor's house in the two upper floors.

## The president of México, Enrique Peña Nieto, inaugurates the San José del Cabo-Cabo San Lucas highway



President Enrique Peña Nieto of Mexico presided the inauguration ceremony of the San José del Cabo- Cabo San Lucas highway in which FCC was involved and built the four junctions that connect the highway to secondary roads. Also at the event were the secretary of communications and transport, Gerardo Ruiz Esparza, the governor of Baja California Sur State, Carlos Mendoza Davis, the president of the municipality of San José del Cabo, Arturo de la Roca Escalante, and other relevant authorities.

FCC was represented at the ceremony by Enrique Díaz Valdés, country manager of FCC Construcción México, and Juan Antonio Hernández Carrillo, manager of the Construction II Department.

The 38.7 kilometre infrastructure required an investment of 147million euros

(2,500 Mexican pesos). It will benefit about 238,000 people who live in the towns of La Paz and Los Cabos.

The highway is part of the priority infrastructure plan to support the tourism business in Baja California Sur by:

- Boosting the tourism and commercial activity in both cities.
- Reduce travel time from one town to another from 40 to 17 minutes.
- Improve mobility between the International Los Cabos Airport and the tourist destinations in the state.

# Vitoria installs containers adapted for the disabled

The FCC and GSM SM joint venture started to install the new waste and recycling containers in Vitoria-Gasteiz.

Gradually, a total of 3,000 containers for paper and cardboard, plastic, and other types of waste, excluding those for glass or the orange ones for organic waste, will be replaced.

These recycling islands, the name given to these containers, are part of the new cleaning contract. The structure of the containers is made with polyethylene instead of the plastic used in the existing containers. They stand 1.80 metres tall and have a capacity of 3,200 litres. All of these containers

will be adapted and will be more easily accessible since they feature a special lid at a height of 90 centimetres from the ground that can be used by those with disabilities.

A new system, using a special truck, will be used to clean the containers.

To date, 40 containers 1.5% of the total have been replaced and the plan is to renew 10% of the remaining containers every year.



## New containers

3.200 L CL

**Adapted for the disabled**  
A loading hatch situated 90 cm from the ground for people who use a wheelchair.

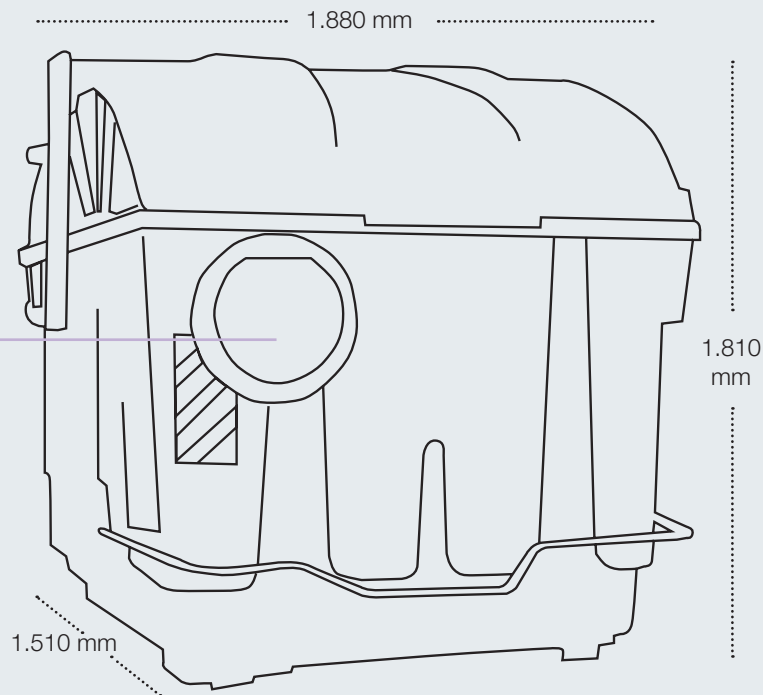

**Manufactured with injected polyethylene.**

**Resistant to chemical products and atmospheric agents.**

**Adapted for side-loading waste collection trucks**

## More than 58,000 tons of waste

Vitoria-Gasteiz has a population of more than 242,000 people who produce 58 tons of waste every year that is removed and transferred everyday to a waste treatment plant for its handling.

The FCC-GSM SM joint venture has implemented a 6-day-a week waste collection

service and will be paying special attention to the cleaning services in the historic district, also providing services in industrial zones.

These services will involve an investment of more than 13 million euros that will be spent mainly in purchasing new machinery, including 33 sidewalk sweepers (one of them running on electricity), 5 street sweepers, 9 side-loading collection trucks, 22 sweeping porters (9 of them running on electricity) and 9 electric inspection vehicles.

# Lleida City Council praises FCC Aqualia's water cycle management

The Department of Urban and Rural Habitat and Sustainability issued a press release in which it praises the great work of Aqualia in managing the city's water cycle. The information is based on the positive data submitted in the Monitoring Committee.



Some of the members of the Aigües team in Lleida.

“  
The City Council highlights the numerous benefits enjoyed by Lleida and its residents as a result of the indirect management of the water services

”

Under the heading “Lleida makes progress in improving the potable water supply network and the sewerage system”, the City Council of Lleida sent a note to the media praising FCC Aqualia's management in the city over the past few years. “The deputy mayor and council member, Félix Larrosa, defended the greater efficiency of indirect water management of the water and sewerage department rather than other options due to the greater investment capability, the economies of scale, the company's knowledge of the sector, its technology, constant innovation, and management skills”.

Some of the other measures that the Council praised included the significant reduction of the city's water consumption thanks to the constant work being carried out to create environmental awareness among the population, policies to save water, the 35% increase in the water yield, the investments made, and the creation of the social tariff.

The wastewater treatment plant in Lleida was also praised since in the last few years “considerable improvements were made in the water treatment, a cogeneration engine was installed which generates from biogas 33% of the electricity consumed at the plant”.

The councilman also mentioned that Aigües de Lleida was the first Spanish company to be awarded the environmental seal for reducing CO<sub>2</sub> emissions and for energy sustainability in the end-to-end water cycle.

# Communication prize; everyone's success

FCC Aqualia was recognised as the most influential company in the water sector in 2015. The prize, organized by iAqua, rewards the achievements of people and the leading organizations in the water industry. Félix Parra, managing director of FCC Aqualia, collected the prize from Alejandro Maceira, the managing partner and founder of the publication. During his speech, Félix Parra expressed his appreciation for the award, “the result of the company’s client-focus and its commitment to transfer to society the value that we contribute in the regions where we operate”. According to the information included in the

ranking, FCC Aqualia (11,624 points) scored first by a wide 3,000 margin in comparison with Aqualogy, the second-ranking company and last year’s prize-winner. As underscored by Juan Pablo Merino, director of Communications and Corporate Social Responsibility at FCC Aqualia, “the prize was obtained thanks to the efforts of the entire FCC Aqualia team which not only performs an excellent job, but also increasingly informs the community about its work and the high added-value work that the company provides for the citizens”.



A moment at the ceremony when Félix Parra expresses his appreciation for the prize.



Family photo of the award-winners in the different categories of the iAqua prize.



# Two FCC projects win the prizes awarded by the Association of Civil Engineers of Madrid



FCC won two of the prizes granted by the Association of Civil Engineers of Madrid in the 2015 award ceremony which took place in the Casa de América in Madrid. The construction of the junctions of Sector AR Tres Cantos won the prize for the best municipal civil works while Line 1 of the Panama Metro was awarded the prize for the best project abroad.

The prize for the Tres Cantos road project was given by Pedro Rollán, the councillor of Transport, Housing, and Infrastructures of the Madrid Autonomous Community, Jesús

Moreno, the mayor of Tres Cantos, and Miguel Jurado, chairman of FCC Construcción.

Jesús Moreno said that “the construction of these roads and the junction with the M-607 facilitate mobility and the access to services of more than 30,000 residents of Madrid”.

The panel of judges highlighted the complexity of the project and the solutions provided to facilitate access and the evacuation of traffic generated by the implementation and development of the new Sector A.R. of Tres Cantos. Miguel Jurado, the chairman

of FCC Construcción added that “this is a great engineering project in which the FCC teams built junctions to avoid crossing other existing infrastructures, such as the M-6’7, the High Speed Madrid-Valladolid railway, and the installations of Canal de Isabel II”.

A prize was also awarded to the “Line 1 of the Panama Metro” Project, sponsored by the Secretariat of the Panama Metro (SMP, Spanish acronym) and executed by FCC, highlighting this ambitious engineering project which benefits more than one million people and which was built in a record-time of three years. Vicente Mohedano, the managing director of FCC Construcción collected the prize and said that engineering is at the service of society and that the project had substantially improved the lives of Panamanians since it only takes 23 minutes to travel from one station to the other one.

# FCC Industrial is developing a system for an Air Force training program



The Systems Division of FCC Industrial completed the development of a monitoring and analysis system for aviation missions which are part of the mission program known as Tactical Leadership Program (TLP) for the Head of the Unit for Contracting and Economic Management of the Air Force. This 3-year and, almost 1.2 million euro contract was awarded to the company at the end of 2014.

Developed by the Citizen Services Group's Industrial Division, the software provides support to the Flight Courses of the Tactical Leadership Program. It is able to reconstruct in 2D and 3d the missions that had been flown using the information acquired from multiple sensors installed on the ground as well as on Air Force aircraft.

These reconstructions are used in the post-flight analysis of the most relevant aspects of the exercises, thereby ensuring quality

tactical training based on combined flight missions in realistic environments.

The system is able to monitor and record in real time the execution of a flight mission with several latest generation aircraft for the subsequent reconstruction and analysis for training purposes.

**FCC Industrial awarded a maintenance contract for the Malaga-Costa del Sol Airport facilities**

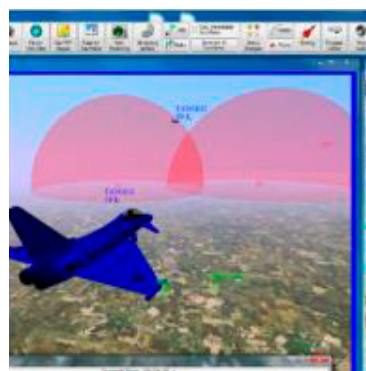
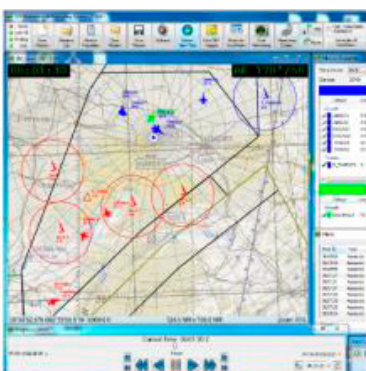

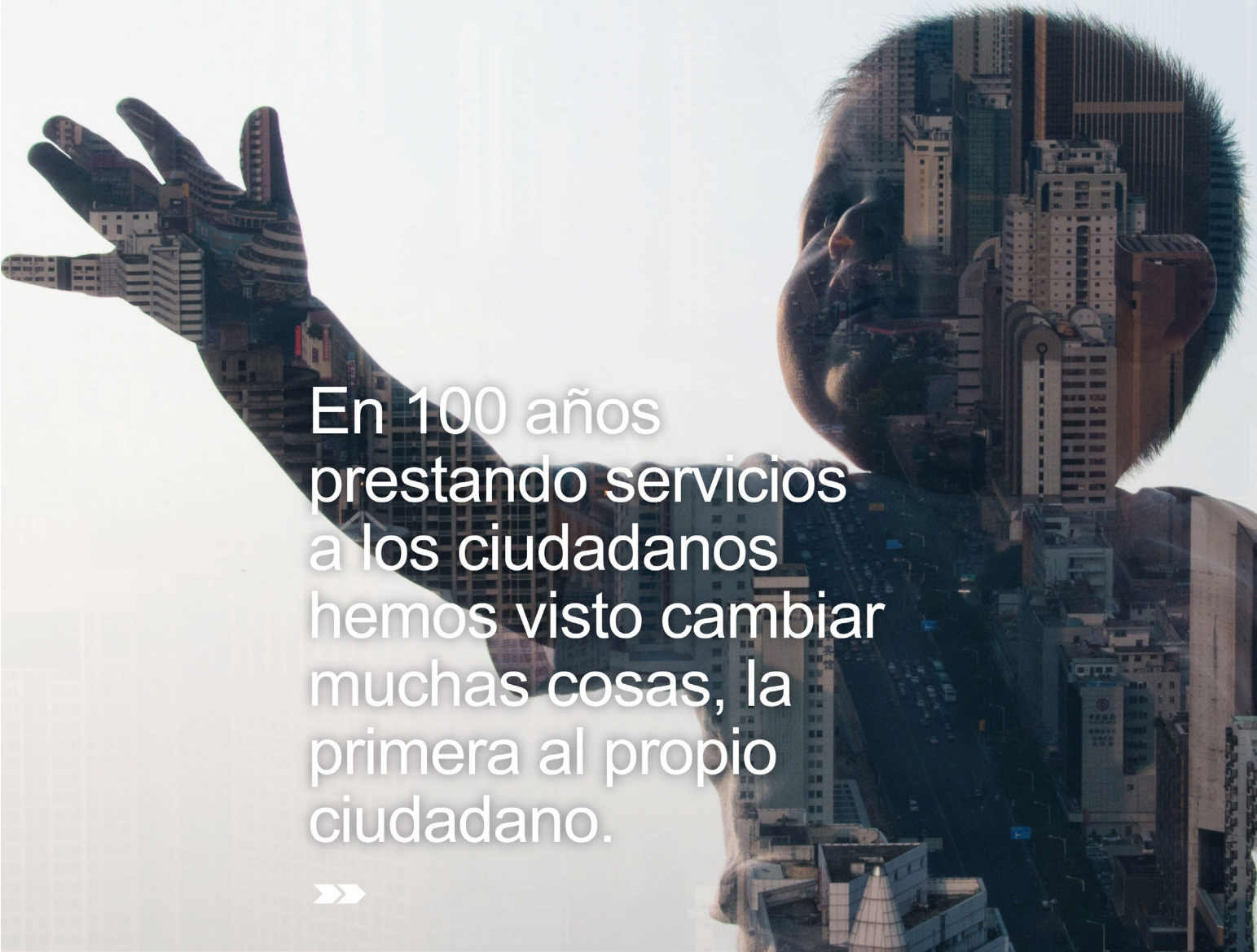

En 100 años  
prestando servicios  
a los ciudadanos  
hemos visto cambiar  
muchas cosas, la  
primera al propio  
ciudadano.



En FCC diseñamos y construimos infraestructuras, recogemos, reciclamos y valorizamos residuos urbanos e industriales, limpiamos calles, cuidamos parques y jardines, mantenemos el mobiliario urbano y suministramos agua en 5.000 municipios de todo el mundo desde hace más de 100 años. Al principio éramos unos pocos preocupados porque millones de personas disfrutasen de un lugar mejor donde vivir. Hoy son esos millones de personas los primeros que se preocupan por crear un lugar mejor donde vivir.

Lo estamos haciendo juntos.

# People



## FCC participates in the program and scholarship award ceremony of Fundación Prevent

Fundación Prevent celebrated the 11th Prevent Scholarships Award Ceremony. These scholarships are awarded to university students, entrepreneurs, and sportsmen, all of whom have some type of disability, rewarding their talent, innovation, health, and social inclusion. Once again, 750 people filled the Palau de Congressos Auditorium in Catalonia to accompany the 45 athletes from the Catalan Sports Federation for persons with physical and visual

disabilities and with cerebral palsy who, in 2015, stood out thanks to their perseverance and their national and international success.

Cerebral palsy was the central theme of the entire event: Fundación Prevent wanted to focus, through its first documentary film, on this disability of which little is known and which is surrounded by fear and prejudice. In Spain, 120,000 people suffer from this disability according to data from ASPACE, a non-profit entity declared of public interest which groups together the organizations that provide services to those with this disability throughout Spain.

Executives and volunteers from several multinational firms were on the stage to greet some of the 49 young university students, the talented individuals, who won

the award in search for opportunities to contribute and to create a more competitive and responsible job market.

FCC was represented by Ana Villacañas, the managing director of Organization, who as a specialised mentor, accompanied one of the entrepreneurs in this second edition of the award.

During the award-ceremony, scholarships were awarded to research projects on the Prevention of Occupational Hazards; sports; training to be able to continue with a university education; and scholarships for young entrepreneurs with disabilities and great development potential.

### Training and mentoring program

This training and mentoring program is designed for entrepreneurs to enable them to start-up a business project. The project has counted with the collaboration of ESADE and the disinterested participation of private companies that are references in their business sector, such as FCC, since, one of the objectives of the Group's Corporate Social Responsibility is to promote equal opportunities and ban all types of discrimination in the hiring process.



Link documental  
<https://youtu.be/sDzh0Y1ZGWE>

# Nine FCC Group women successfully complete the Career Development Program for Women with High Potential

Ana Virginia Arroyo Obis, Yolanda Barahona Borja, Marta Casao Maestre, Ángela Buendía Herrero, Ruth López Pasarín, Carmen Elvira Romero Oliver, Cristina Sarti Tercero, María Izquierdo Sans and Ana Isabel Pérez Ocón successfully completed the sixth edition of the program aimed at pre-managers with high potential that was carried out at Escuela de Organización Industrial (Industrial Organization School, EOI Spanish acronym).

Elena Mayoral, the manager of Adolfo Suárez Airport, was present at the closing event. She gave out the diplomas and made a short speech to the women who had participated in the program, saying that: "Companies need men and women who form cohesive teams to meet challenges. The key to success is nothing other than work, work, and more work".

This training program is promoted and partially funded by the Ministry of Health, Social Affairs, and Equality through the Secretariat of Social Services and Equality. The objective of this program is mainly to provide comprehensive training to prepare these women to assume have greater managerial responsibilities in the future based on a multidisciplinary perspective. Its primary goal is to create awareness in companies on the benefits of having feminine talent and to advance towards a balanced breakdown of men and women in key decision-making jobs.

The course was developed from April to November 2015, combining classroom sessions with online training. The subjects studied over the course including finance, management skills for the management of efficient and motivated teams, operational management to learn about the functionalities of the corporate organization, management of companies to discover the keys to innovation and to identify business opportunities, as well as an individual coaching process.



# First meeting of FCC Aqualia's senior management following the implementation of the new organizational



The managing director of FCC Aqualia, Félix Parra, gathered a large group of executives in a meeting at the Las Tablas headquarters, to analyse the new phase in the company following the approval and implementation of the new organizational structure.

The analysis and general guidelines of the impact of the new organizational chart was the key theme of the meeting where "all FCC

Aqualia activity is integrated in a single production line for all business models: water public service concessions, provision of BOT, DBO and EPC services, except those from projects considered unique", said Félix Parra, elaborating on the information note distributed throughout the organization a few days earlier.

The other executives who participated in the meeting included Luis de Lope, mana-

ger of the international division; Javier Santiago, who will be in charge of managing the new Water Engineering and Technology Department; Pedro Rodríguez, head of Studies and Operations; and Santiago Lafuente, who described the master lines of the Spain division.

Carlos M. Jarque, CEO of FCC, was present in the working seminar. He described the situation in the Group's three business lines, Construction, Environment, and Water Management, pointing out that Aqualia is doing an excellent job both within the Group as well as in its business sector, being one of the reference companies worldwide". He congratulated all the Company's workers and encouraged them to continue working every day to "maintain and increase our presence in Spain and grow in international markets".

## Potency 2015 prizes FCC Construcción awarded prize

The Potency of Machinery in Public Works and Civil Engineering prizes celebrated its ninth edition. It has become one of the most relevant events for the sector and one which is worth attending to learn about the trends in machinery and the projects made in the infrastructure projects being developed by construction companies.

FCC Construcción won a Potency 2015 prize in the category of land routes. José Manuel Illescas, manager of Machinery at FCC Construcción, collected the prize for



the A7Mediterranean Highway, Carchuna-Castell de Ferro (Granada) section, executed by the General Department of Roads of the Ministry of Infrastructures. An honorific Potency 2015 prize was also awarded to Antonio Muro Morillo in recognition of his more than forty-year career in the sector.

## United Kingdom

# The Mersey Gateway team creates new children's playgrounds



The team at Mersey Gateway, a consortium of which FCC is a partner, has inaugurated a new children's playground in Widnes. The project responds to the request submitted by the Time Bank Community Centre in Merseylink and was created to support the projects of the local community.

The new recreational area at the West Bank Community Centre was inaugurated at a special ceremony with children from Wid-

nes who were able to enjoy the new equipment, including a trunk-shaped train, a pirate ship, structures for climbing and wood posts, as well as benches, a snack area, and access facilities for the disabled.

The children's playground, which cost 27,000 pounds sterling, was financed by the Merseylink Regeneration Fund and the contribution of employees and several suppliers.

Councilman Rob Polhill, the mayor of Halton and chairman of the Mersey Gateway Crossings Board said that: "Our communities are the heart of Halton and it is fantastic that local organizations such as the Community Centre can benefit from the Mersey Gateway Project".

# The employees in Oviedo are extraordinarily committed to local social actions



was, proportionally the one with the highest number of registered participants. The Aqualia team was also able to encourage the participation of the City Council and of the media who covered the event extensively.

All of the business areas of Aqualia in Oviedo who collaborated in one of the social projects developed by the Company were present at the event: Ricardo Álvarez, Client manager for the drawing contest; Miguel Toyos, head of procurement for his work in Social Networks; David Casado, head of Production for disseminating the technological innovations in the social networks; Sonia López, head of Quality, who coordinated the tours of the Wastewater Treatment Plant; Jorge Suárez, head of the Laboratory for organizing the open-door seminar; Juan José Viña, head of the Technical Office as the person responsible for training students; Paloma Gurriarán, head of Administration for the fight against Gender-based Violence; Ana Isabel Rosa, Client manager for her work during the Christmas season with the Red Cross; and Ruben Casado, of the Personnel Committee for his involvement in the Food Bank.

The FCC Aqualia team in Oviedo was congratulated for the work carried out in the International Children's Drawing Contest which has reached its 13th edition. In an event held at the city's Auditorium, the members of the Aqualia team, headed by their manager, Alfonso Tomás, received the congratulations of Santiago Lafuente, the national manager of Aqualia, who was accompanied by Juan Carlos Rey, manager of the Zone I office, and by Francisco Delgado, manager of the North branch office.

## The organizational efforts

Thanks to the organizational and promotional efforts of the team in Oviedo, the city

This action aims to recognise the day-to-day work of FCC Aqualia professionals who, besides complying with the public service commitments, are involved in initiatives with great added social value.

Accede a las ofertas publicadas en este momento



# Movilidad Interna

# Congratulations

## to the winners of the FCC Construcción children's drawing contest!



We already have winners for the drawing contest organized by FCC Construcción for the children of employees (4-12 years old) the theme of which this year was Christmas. Carmen Martín won the first prize; Ágata Cabadas the second prize; and Christine Suzette won the third prize.

Construcción team: Cristina Marqués, from Unit Control; José Luís Gascón y Marín, from Planning,; Laura Guirado, from Business Development; Donato Jiménez, from the Accounting Department; Ana Cano, from Studies and Contracts; and Juan Ramón Panea, from the Invoice Management Centre.

The winners were selected by a panel of judges made up of six members of the FCC

# Congratulations young artists!

## The winners of the most international contest

The number of countries where the contest was carried out increased to six: Spain, the Czech Republic, Mexico, Chile, Uruguay, and the United Arab Emirates.

The names of the winners and finalists of the 4th Edition of the Peque-Artistas Contests are available at Aqualia's intranet and at the [www.llenatumundodevidaenaqualia.es](http://www.llenatumundodevidaenaqualia.es) website.

The number of participants in this year's edition increased threefold. Hence, 175 children from the ages of 5-14, children or grandchildren of FCC Aqualia employees, participated in this edition. The initiative, which was developed in a digital environment to encourage children's skills in the use of new technologies, was a great success among the smallest members of the FCC Aqualia family.

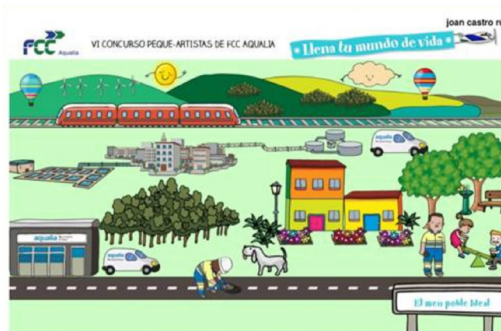

The award-winning work of the child: Joan Castro, de Denia (Alicante), Spain

One of the most noteworthy aspects of this edition was the large involvement of FCC Aqualia employees and their children in the countries where the company conducts its activities: Spain, the Czech Republic, Mexico, Chile, Uruguay, and the United Arab Emirates.

All of the participants used the tools provided by the contest's technological platform to bring to life their ideal environment and give it the name that they liked the most.

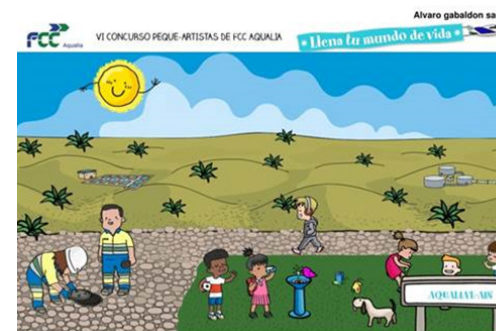

The award winning work of the youngster Álvaro Gabaldón Sánchez, from the United Arab Emirates.

They brought people, animals and plants to water, just as the water company for which their parents or grandparents do on a daily basis.

The prizes awarded were two Samsung Galaxy tablets for each of the winners of each category (children and adolescents) and 10 educational "My first vegetable garden" games for each finalist (five for each category).



# Social Responsibility

Pinta el mundo de **NARANJA**

PON FIN A LA VIOLENCIA  
CONTRA MUJERES Y NIÑAS

#orangetheworld

CHE

ARA

ESP

ALE

BUL

ENG

FRA

HUN

ITA

POL

POR

RUM

SLK

SRB

## FCC takes part in United Nations Orange Day for the elimination of gender-based violence

Every year on 25 November, the International Day for the Elimination of Violence against Women, FCC calls upon all employees to remember the company's principles and promote its commitment and vision: zero tolerance towards gender-based violence and to encourage social and professional integration of female victims.

This year the FCC Group is taking part in the United Nations international campaign

"Paint the world orange", with voluntary actions in all countries where FCC is present.

The campaign has been translated into 14 languages and, specifically for the purposes of supporting this day, FCC will carry out different activities, amongst which are photo exhibitions and video projections, handing out orange ribbons, mass mailing all of its employees and spreading the hashtag #orangetheworld on social networks. The

company will also share news, information and important material relating to this day on the intranets and websites.

FCC has invited the employees forming part of the Group to wear something orange on this day (a ribbon, a scarf or whatever they consider appropriate) in order to collectively say no to gender-based violence. Many people, departments, divisions, and countries took part in this initiative.

In Spain, FCC is also participating in the campaign to raise awareness of gender-based violence which is organised by the Ministry of Health, Social Services and Equality, entitled "If there is a way out of gender-based violence, it is thanks to you". GET INVOLVED".

### Commitment

FCC has renewed its commitment with the public authorities and social partners and will continue to carry out internal awareness actions so that others are conscious of the need to eradicate this social scourge and alleviate its effects on victims.

The key to success lies in transmitting a vision of change, progress and awareness to all members of the Group, applied to all actions whose aim is to put an end to violence against women, particularly by increasing communication in the different countries in the world where these practices are present.



See Link

More information:

FCC takes part in the campaign against gender-based violence organised by the Ministry of Health, Social Services and Equality



2015 International Day for the Elimination of Gender-based Violence



Campaign against Gender-based Violence. Daisy, he doesn't love me: Employee messages



## FCC Aqualia, always against gender-based violence

FCC Aqualia launched a second edition of its "Yo, contigo" (I'm with you) campaign to create awareness in the community in general and, particularly, among the Company's workers, on this social scourge.

Twitter, the social network, was used in this initiative, disseminating messages with the tag: #Aqualia dice NO a la Violencia de Género (Aqualia says NO to gender violence). The messages could include individual or group photographs with a poster of the campaign, personalised with the names of those being photographed or the wish that each of them want to express in their rejection of gender-based violence.



The campaign was also disseminated via WhatsApp with an image that was designed to be used during the campaign.

Coinciding with the campaign in the social networks, FCC Aqualia executives and representatives participated in several commemorative events organized in Archidona and Ronda (Malaga), Dénia (Alicante), Avila and Oviedo.



# FCC Industrial México: “16 days of activism against gender-based violence”

Coinciding with the International Day for the Elimination of Violence against Women, FCC Industrial Mexico launched the “16 days of Activism against Violence against Women and Girls”.

The tasks developed during the campaign included the distribution of information leaflets, awareness seminars at the different projects being developed by FCC Industrial Mexico, information panels and seals, and orange ribbons attached to the work clothes of employees and vehicles. Orange-coloured insignia were also distributed to men and women in the regions where FCC Industrial conducts its activities.

The success of the campaign is based on the collaboration of each and every worker who adheres to the slogan “Violence against women and girls can be eradicated”.

This campaign is in keeping with the equality and diversity policies developed by the Company’s Human Resources Department for the purpose of ensuring that employees work in an environment that promotes equal opportunities and effective equality.



## Committed to equality

This year, the Ministry of Health, Social Services and Equality awarded FCC Industrial the Equality in the Company seal. This excellence seal is a stimulus and recognition for organizations who are committed to equality and which have implemented policies aimed and promoting it in every area of the company.

The award to FCC Industrial of this seal is the follow-up of the seal obtained in 2009 by FCC Construcción, the first company in the sector that launched an equality plan.

“

The slogan  
of the campaign:  
“Violence against  
women and girls can  
be eradicated”

”

# SI HAY SALIDA A LA VIOLENCIA DE GÉNERO ES GRACIAS A TI.

## ÚNETE

LLAMA  
AL  
016

VAMOS  
A  
APOYARTE

ESTAMOS  
A TU  
LADO

ÚNETE

CUÉNTALO  

LLAMA  
AL 016

VAMOS A  
AYUDARTE

ESTAMOS  
A TU  
LADO

ÚNETE



# FCC supports the International Day of Persons with Disabilities

Coinciding with the commemoration on 3 December of the International Day of Persons with Disabilities, FCC maintains and reinforces its commitment to those with disabilities on a daily basis by promoting measures and projects to encourage equality through employment.

In all parts of the world and at all levels of each society, there are people with disabilities. Ensuring equal opportunities is one of the organization's unwavering commitments and, for FCC, equality means respecting the differences.

FCC reinforces every day its commitment to this group by promoting actions and projects to encourage equality by means of employment.

As part of the Inserta Program, from the beginning to the end of last year, 220 people with disabilities were hired. Renewing this commitment in May of this year, FCC expects to hire 125 more people over the next three years.

This challenge is totally in line with FCC's business model; responsible and efficient, go-

verned by the principles of equality, diversity, integration, and sustainability, generating profitability and productivity.

In compliance with the United Nations Declaration on the Rights of Disabled Persons, FCC recognises the right of the disabled to employment under equal conditions and opportunities, in a job freely chosen or accepted within an open, inclusive, and accessible work environment.

Moreover, at FCC, in accordance with its equality and diversity policy, work practices are implemented and maintained to ensure that no member of the workforce or potential candidate, is treated unfairly because they have a different capability or for any other unjustified reason that has nothing to do with the professional skills, knowledge and performance.

Last year, the FCC Group subscribed the Diversity Charter of Spain, an initiative through which the company reinforces its commitment to the fundamental principles of non-discrimination at the work place, support of diversity, and respect for the differences among people. The Group renewed its commitment once again this year.

For further information:

## Álbum de fotos

Día Internacional de las personas con discapacidad  
3 de diciembre 2015





# 3 DECEMBER INTERNATIONAL DAY OF PERSONS WITH DISABILITIES

In honour of International Day of Persons with Disabilities (3 December), FCC would like to emphasize its constant commitment to this group in the form of actions and projects to promote equality through employment.

In compliance with the United Nations Convention on the Rights of Persons with Disabilities, FCC recognises the right to work on an equal basis with others, and the right to the opportunity to gain a living by work freely chosen or accepted in a labour market that is open, inclusive and accessible to persons with disabilities.

In coherence with our policy on equality and diversity, FCC implements and maintains labour practices which ensure that no employee or candidate receives unfavourable treatment as a result of being differently abled or for any other reason which is unjustified and unrelated to skills, knowledge and professional performance.

Equal opportunity is an irrevocable principle of the organization. For FCC, equality means respecting differences.



## People who can make a significant contribution

The theme chosen by the United Nations this year for this commemoration is: "Inclusion matters: access and empowerment for people of all".

According to United Nations data, it is calculated that one billion people in the world have a disability. As a consequence of this, unlike other people, their access to society is not the same in areas such as transport, employment, education, and political and social spheres. Promoting the strengthening of this group creates real opportunities for people, promoting their skills and helping them to establish their priorities.

Empowerment means investing in people – in jobs, health, nutrition, education, and social protection. When this is the case, they are better prepared to seize opportunities, they become agents of change, and they can assume their civic responsibilities when they are better prepared.

Under these general premises and in keeping with its Corporate Social Responsibility and Human Resources policy, Aqualia collaborates throughout the year with the Ministry of Health, Social Affairs, and Equality. Part of this collaboration involves donations to entities that conduct their activity in the cities and towns where the Company provides its services and which work with the disabled to help them improve the quality of their lives.

FCC Aqualia has selected five organizations to which it will make a donation to help them execute the five specific projects that these entities are carrying out. These organizations conduct their commendable activities in Oviedo, Segovia, Jerez, Villena and Formentera/ Ibiza.

# 3 DECEMBER INTERNATIONAL DAY OF PERSONS WITH DISABILITIES

# 3 de DICIEMBRE DÍA INTERNACIONAL DE LAS PERSONAS CON DISCAPACIDAD

# 3 de DICIEMBRE DÍA INTERNACIONAL DE LAS PERSONAS CON DISCAPACIDAD



The International Day of Persons with Disabilities" this year is commemorated under the theme: "Inclusion matters: access and empowerment for people of all abilities".

## Special prize from Fundación Integra after hiring 100 persons at risk of exclusion

The minister of Employment and Social Affairs, Fátima Báñez, has awarded the FCC Group one of the special prizes granted by Fundación Integra on its 10th anniversary.

The prize recognises FCC Group's involvement and support in this project of the foundation that has resulted in the hiring by FCC

of more than 100 persons at the risk of exclusion or with some sort of disability.

Ana Botella, the chairperson of the Foundation, gave FCC another award for joining the Integra Commitment Project, a network of companies and entities committed to socially responsible employment. Thirty-one

companies and entities that are committed to the inclusion in the workforce of persons in a social exclusion situation have already become part of this network.

## FCC Construcción once again included in the Carbon Footprint Register

FCC Construcción renewed its registration in the Ministry of Agriculture, Food and the Environment's Register for the carbon footprint, compensation, and projects for absorbing CO<sub>2</sub> emissions (MAGRAMA), thereby reaffirming its commitment to sustainability. FCC was the first construction company to register its carbon footprint in 2013 in the MAGRAMA register and in the following two years surpassed its reduction target.

The purpose of the seal is twofold: it makes it easier for organizations to demonstrate their participation in the register; and makes it possible to reflect the degree of the companies' efforts in the fight against climate change.

FCC Construcción is currently participating in the "One million for the climate" campaign, an initiative the purpose of which is to reinforce the overall commitment, adding up all the individual and group actions that have an impact on the climate to underscore the urgency of an ambitious emission-reducing policies to prevent the worse ecological, economic, and social impacts of climate change.



GOBIERNO  
DE ESPAÑA

MINISTERIO  
DE AGRICULTURA, ALIMENTACIÓN  
Y MEDIO AMBIENTE

# Learning through fun



Service for the Future is the claim which has been connected with our company for almost 10 years. It describes the very essence of our business; transforming waste into resources, improving living conditions in the cities, as well as eliminating ecological burdens with our remediation projects.



One of the ways that we think about our future is by educating the future generations - our children. Annually we share our knowledge with about 700 schools and kindergartens in 4 countries (Czech Republic, Slovakia, Serbia and Poland). In the Czech Republic in particular, we can be proud of the 15 year history of our country-wide, secondary raw material collection competition. Thanks to this program we collected about 4.300 tons of paper during the last school year. The children and schools are rewarded for this initiative with promotional gifts, art supplies, sport equipment and financial support.

Excursions to our plants are also very popular among the schools and children, with many of the kids who come for a visit longing to be dustmen or women afterwards! In December 2015 the Brno plant welcomed another group of children from a school, who learned how the waste treatment process runs and also how important it is for us all to support the right separation of waste and to protect the environment.

## FCC Aqualia prepares a report on the management of the carbon footprint

FCC Aqualia has prepared a report to inform on the basic concepts related to climate change and the carbon footprint. The objective is to create awareness on the threat for the planet's sustainability due to climate change and, thereby, to reduce the company's carbon footprint.

As part of its environment-friendly strategy, FCC Aqualia is committed to registering and reducing the carbon footprint in all the activities that it conducts. This implies measuring and reducing the total amount of emissions

of CO<sub>2</sub> and other Greenhouse Gases (GHG) caused directly or indirectly by our Company.



Report on the management of the carbon footprint at FCC Aqualia

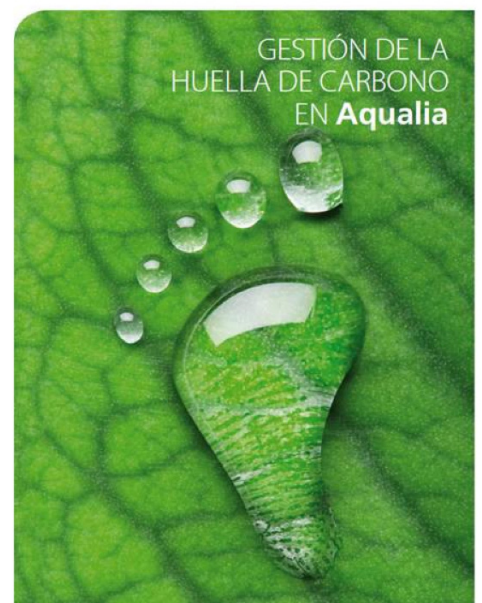

[www.aqualia.es](http://www.aqualia.es)



# New alliance for equality

FCC Aqualia, UGT and CC.OO. renew their Equality Plan which includes a set of specific measures to be implemented from now until 2018

FCC Aqualia and the two most important trade unions nationwide (UGT and CC.OO.) have renewed the Equality Plan that the Company has been implementing since 2009, the year in which the Company's First Equality Plan was signed.

The signing ceremony took place in the Las Tablas headquarters in Madrid. The Company representatives included Carmen Rodríguez, manager of Human Resources, and María Ángeles Polo, in charge of Recruitment, Training and Development. Representing UGT, the signatories were Gustavo Vargas, secretary general of FCC Aqualia's Trade Union Section, and Diana Junquera, the person in the trade union responsible for the Women's Department. Comisiones Obreras (CC.OO.) was represented



In the photograph, a moment during the signing ceremony at the Las Tablas headquarters.



From left to right, the signatories of the document: Mayte Sola, María Ángeles Polo, Fernando Antón, Gustavo Vargas, Carmen Rodríguez and Diana Junquera.

by Fernando Antón, the secretary general of Citizen Services, and by Mayte Sola, the Women at the Service of Citizens area.

The agreed plan, which will be in force from 2015 to 2018 and which will be implemented at all FCC Aqualia worksites, contemplates a set of specific measures covering various aspects access to a job, promotion, training, remuneration, conciliation, the prevention of harassment, and other informative measures to create awareness and to incorporate equal opportunities in the Company's policies.

In this way, FCC Aqualia reinforces its commitment to the fight against inequality due to gender and in favour of equality in the treatment and in the opportunities of both men and women.



The agreement is in keeping with the Company's strategy aimed at eliminating gender-based inequality



# Instagram contest



Finalización del primer tramo de la línea 5 del Metro de Riad. Tomás Arranz.  
Finishing the first tunnel section of line 5 of the Riyadh Metro.



Pasarelas de Lusail. Víctor Gómez.  
Pedestrian bridges in Lusail.



Construcción del nuevo colegio alemán en Madrid. Sergio Santos.  
New Deutsche Schule construction in Madrid.



Construcción de los cofferdam del puente de Mersey. Fernando Flores.  
Cofferdam construction in the Mersey Bridge.UK



Llegando a Los Andes. L1 del Metro de Panamá. Marta Martín  
Arriving at The Andes. L1 Panama Metro.



Paso del tren junto a la vía restaurada en el corazón de las líneas de ferrocarril en Transilvania. Mario Martínez



Presa de Castrovido. Agustín Peralta.  
The harsh winter in the province of Burgos. Castrovido Dam.



Acabando las pilas del viaducto récord mundial en arco ferroviario. Viaducto de Almonte. AVE Alcántara-Garrovillas. David Carnero.  
Finishing the piers over the world record arch of a railway bridge. Almonte Viaduct. Alcántara-Garrovillas HSR.

## Winners of the 12 best photographs of FCC Construcción projects

We present the twelve prize-winning photographs of the Instagram contest. The contest is concluded following the broad participation internationally with twelve images that show the activity and magnitude of FCC Construcción's activity in infrastructures worldwide.



Construcción de la nueva torre de control del aeropuerto del Dorado. Manuel Peña

New control tower construction in El Dorado airport.



Viaducto Borja Gil Navarrete. Autopista de Nuevo Necaxa-Tehuacán. Enrique Díaz.

Borja Gil Navarrete Viaduct. Mexico Nuevo Necaxa - Tihuatlan Highway



Torre principal del Puente Gerald Desmond. Julio G.Ruiz.

Main tower in the Gerald Desmond Bridge.



Puerto del Callao. Helios García.

Callao Port.

# Cybersecurity, everyone's responsibility

Interview with  
**Miguel Rego,**  
managing director of  
the National Institute  
of Cybersecurity



“  
The general objective  
of the institute  
is to strengthen  
cybersecurity and  
trust in the services  
of the Information  
Society  
”

The National Institute of Cybersecurity (INCIBE, Spanish acronym) is the competent entity for the development of cybersecurity and for citizen's trust in digital issues, the academic network and for Spanish research (Re-dIRIS), and companies, strategic sectors in particular.

The activities conducted by INCIBE are supported by three fundamental pillars: providing services, research, and coordination.

**Services.** Promotes services in the field of cybersecurity that make it possible to take advantage of Information and Communication Technologies (ICTs) and increase trust in digital technologies. Specifically, INCIBE is involved in the protection of users' privacy, encourages the implementation of mechanisms for preventing and addressing information security incidents, minimising its impact when these incidents occur, and promotes the advancement of the information security culture by building awareness and through training.

Research. It has significant capabilities for tackling different types of complex projects with a strong innovation component. The dynamics of its operations is also focused on research, hereby enabling INCIBE to have the ability to generate intelligence in cybersecurity as the driver behind its application in new technologies and mechanisms that also contribute to improving services.

**Coordination:** Participates in collaboration networks that make it possible to respond in the field of cybersecurity immediately, globally and effectively, always with a perspective based on experience and the exchange of information. This is why for the activity conducted by INCIBE, coordination and collaboration with other entities, private or public, national and international, is essential.

Miguel Rego, the managing director of INCIBE, an expert in this field and highly respected by professionals in the private and public sectors, explains the mission of the institute, to whom it reports, and how it is organized, and also stresses the importance of cybersecurity for companies.

## What is the mission of the National Institute of Cybersecurity?

The general objective of INCIBE is to reinforce cybersecurity and trust in the services of the Information Society. It contributes value to citizens, companies, the Administration, the Spanish academic and research network, the information and communication technologies sector and strategic sectors in general. This translates into more specific

goals. On one hand, consolidating INCIBE as a relevant player in the national and international cybersecurity field and as the promoter of the ICT sector and of cybersecurity.

On the other hand, it aims to monitor the constant evolution of incident-response services (through our Security CERT and Industry-CERT\_SI) and deploy new capabilities based on INCIBE's potent technological platform. These objectives can be summarised as a general objective to improve society's digital trust by building awareness, training and the generation of talent, and on the technical capabilities of an entity such as INCIBE with a deep public service vocation.

## To whom does INCIBE report and how is it organized?

INCIBE is a company reporting to the Ministry of Industry, Energy and Tourism (MINETUR), managed through the Secretariat of Telecommunications and the Information Society (SETSI, Spanish acronym). As an excellence entre, INCIBE is the Government's instrument for developing cybersecurity as the driver of social transformation and the opportunity for innovation. To this end, with an activity based on research, the provision of services and the coordination with agents with competencies in this field, INCIBE is the leader in different cybersecurity-related actions nationally and internationally.

As concerns its administration, INCIBE has about 90 employees. Nevertheless, it counts with practically all the companies in the Spanish cybersecurity sector. I would like to highlight as an important part of our corporate culture the fact that INCIBE is a company always willing to collaborate and cooperate, as shown, to cite some examples, its close relations with the Ministry of the Interior, with the Organization of American States, and with private companies such as Microsoft.

## Do you think that companies are prepared to tackle cyberthreats?

Considering that not all companies have the same possibilities, either because of their

sector or because of their volume, all are concerned with cybersecurity and the risks that it entails. SMEs and companies listed in the IBEX35 index are all aware that cybersecurity is essential in order to be able to face current threats and are convinced that cybersecurity must be part of the company. It has been confirmed in the various editions of CyberEx, that participating companies have made significant investments in cybersecurity and the results show that the technical teams are very capable of responding to everyday problems. The level of specialisation at major companies is high and their concern for being prepared for any incident is evident in all sectors. Each year, the scenarios of Cyber-EX are increasingly complex and companies are aware of the risks and are realistic.

### As an expert in cybersecurity, why should FCC and other major Spanish companies participate in the Cyber-exercises?

Participating in security cyber-exercises enables companies to develop and train a wide range of capabilities. The simple fact of being able to test in-house procedures, improve the exchange of information among the different departments, maintain the alert level of the technical teams, and improve the recovery capability in the event of a disaster are the great challenges regarding which all companies are concerned.

It is important for companies to participate in these simulation exercises so that they are able to know their companies internally, know the divisions or departments that they should contact in the event of an incident, know the response time, identify the points subject to improvement, and focus their procedures in the right direction.

Participating in these initiatives is also a clear indicator of the commitment to cybersecurity, increasingly demanded by investors, clients, and by the public in general.

### What are you expecting for 2016?

2016 brings new challenges and more difficulty for adapting to the threats and the needs of companies. The national edition of the cyber-exercises for Critical and Strategic Operators -CyberEx 2016- will be a multi-sector event, with new scenarios and greater participation than in the previous editions. Following the success and broad acceptance of the first edition, a second International CyberEX will be scheduled in which teams representing various countries will be parti-

cipating with the intention of bolstering the response capabilities in the face of cyber incidents as well as to improve collaboration and cooperation to tackle these types of incidents.

Several initiatives will be carried out throughout the year that make it possible to assess the current state of preparation of the participants in the event of a cybernetic crisis, sharing lessons learned and providing recommendations for the future: aspects subject to improvement so as to make it possible to face a cybernetic attack, to increase cooperation and coordination among the sectors involved, to identify interdependencies, to increase awareness and improve training, etc.



## FCC scores 8 in the latest edition of the cyber exercises

The CiberMS cyber exercises concluded last November. This was the fourth edition of the event that is sponsored by Asociación Española para el Fomento de la Seguridad de la Información - ISMS Forum Spain, and is supported by the National Institute of Cybersecurity (INCIBE) and the National Centre for the Protection of Critical Infrastructures (CNPIC).

The objective of these exercises is to create awareness in major Spanish companies and the community in general on the importance of information security in an increasingly interconnected world dependant on the use of new technologies. The exercises, technical and organizational, demonstrated the capabilities of major companies to detect and respond to threats from the cyberspace. Leaks of information, theft of data, and the refusal to provide services were some of the sce-

narios tested in the simulation.

FCC, as part of its commitment to Safety of Information and Systems, has participated in all of the editions of these cyber exercises. This year, it scored 8 out of 10, a score that was 8 decimals higher than the average obtained by the rest of the participants. Considering this commitment to cybersecurity is everyone's responsibility, the efforts of our group are best examples of our commitment.

### Gianluca D'Antonio

Manager of Information Security at the FCC Group

Information Security and Risk Management Department

# Well-being



## The FCC Medio Ambiente Aragón-La Rioja Branch Office, open seminar for the families of FCC employees

On 12 December, the Aragón-La Rioja branch office of FCC Medio Ambiente, inaugurated the “1st Open Door Seminar” focused on two of the essential pillars of the regional branch: road safety and risk prevention.

All work centres were informed about the seminar so that the family members of FCC employees came to the seminar, especially the youngsters. As the head of the Human Resources Department of Aragón-La Rioja, Carmelo Jiménez, remarked: “the new FCC must be underpinned by enthusiasm

and rediscovering the sense of belonging to the company and its philosophy.” “What better school”, he mentioned, “than learning through the eyes of the children of our workers”.

The seminar went as planned and, after putting on the high-visibility jackets and listening to a brief welcoming speech by the company’s management in the traffic area, the activities began for the two groups of children: one group of ten children from five to seven years old; and a second group of eighteen children with ages ranging from eight to twelve.

The prevention technician of the regional branch was in charge of training both groups on the culture of road safety. The activities were complemented with several discussions aimed at the youngsters on

risk prevention given by members of the Confederation of Businessmen of Aragón (CREA, Spanish acronym) on risk prevention aimed which focused on the following themes: first aid, the use of individual protection gear, preventing risks at home (with real fire), ending with a fun game which illustrated how alcohol affects driving where the children and their parents wore glasses that distorted their vision and had to catch a ball thrown by the trainer and throwing it back.

After a brief lunch break, the young crowd, always under the attentive watch of their



parents, lined up to receive orders for performing tasks, accompanied by volunteers from the various projects and covering a route riding in one of the three vehicles provided by the company.

As can be seen in the photographs, the young children were continuously asking questions about the vehicles and the different services. They enjoyed the event very much. When they cross any corner of the street, they can recognise a vehicle or someone who works for the company and are now more aware of what their parents do when they go to work.

Just looking at the photos of the farewell of each of the groups gives us an idea of what this day meant for them. This was the first event of many more to come, which aim to explain to those who come “what we do and, most importantly, how we do it”, as mentioned by the members of the regional branch.



Driven by a team spirit

## FCC employees participate in the 11 Company Race organised by the ESIC business school

More than 1,046 teams from more than 300 companies, a total of 3,300 runners, participated in the race in Zaragoza. Twenty-seven people in groups of three runners from the FCC Medio Ambiente branch in Aragón-La Rioja participated in the event.

The healthy company concept is making a deep impression in the Aragón-La Rioja regional branch. They sent us a brief article on the companies' race, organized by the ESIC business school, which took place on 13 December.

This is what the Human Resources department of this branch office told us:

Why not participate? Why not run together? If hundreds of workers go out every day to provide services in the city wearing uniforms with the FCC brand: why not go and run a distance of eight kilometres? All together, management and staff, part of a whole, as a team.

Accordingly, a few days after the race was announced, a small Healthy Company space was set up at the driver's traffic office so that the workers who pass by there every day could receive the invitation and obtain the necessary information so that they could participate in the race.

Inspired by the philosophy: If you cannot fly, run; if you cannot run, walk; if you cannot walk, crawl. No matter what you do, keep going forward. Bit by bit, teams registered for the race until reaching a total of 27 participants divided into three groups of runners. As of this race, this figure will certainly increase in future races thanks to the pro-

motion by word of mouth and after looking at the photographs exhibited at the various work places.

The teams...in races, in life, in day-to-day work, teams are built inch-by-inch, adding up, adding the sacrifice and efforts of its members until reaching the goal. This is something that cannot be mandated or enforced; this is not what it is about. Each of the team members will be able to discover that his colleague is by his side and will make sacrifices. This is how we ran the race. This is how we did it as a team.



# FCC among the 8,000 participants in the solidarity “Run for the child 2015” race.

## The FCC Medio Ambiente team winner of the 10 km race

For yet another year, the “Run for the child” race beat the previous record with more than 8,000 taking part. FCC collaborated by donating 100 race bibs which were distributed as follows:

- Participants: 48 women and 52 men
- Ages:
  - 20 participants who were less than 18 years old of which 11 were 3 to 10 years old.
  - The rest of the participants were mainly between 30 and 50 years old, plus another individual who was more than 70 years old.
- About the race circuits:
  - 11 signed up for the 1 km race (6 women and 5 men).
  - 46 participated in the 4 km race (31 women and 15 men).
  - 43 participated in the 10 km circuit (11 women and 32 men).

For the 10 km timed race, according to recorded date, 1,643 runners participated with the best time for the runner wearing the bib with the number 5979 who was able to run the entire circuit in less than 37 minutes and came in 13th place.



In the mini-competition organized by those who registered who formed the team for the 10 km race (seven teams: FCC Montearroyo, Gacelas, Los Aqualios Internacionales, Maratonianos Amigos del Abuelo Palop, FCC Medio Ambiente, FCC Las Tablas, FCC Plus) the FCC Montearroyo, FCC Medio Ambiente, and the FCC Plus teams were finalists.

The winning team with a 00:45:52 average was FCC Medio Ambiente. The team members were:

Y el equipo ganador, con una media de 00:45:52, ha sido FCC Medio Ambiente, compuesto por:

Juan Carlos Inglés Morales  
Jesús Pajares Blázquez  
Juan Regidor Román  
Jesús Barbero Gómez  
Raul Castrillejo Cejudo  
Verónica Lina Palomino López



## Solidarity and sports

The “Run for the child” race is an activity which aims to encourage solidarity and sports. Once again this year, all the proceeds from the sale of the race-bibs will be totally earmarked for the Foundation for Biomedical Research of the Niño Jesús Children’s Hospital.

The proceeds from this edition will be allocated to the following projects: video-recording in the paediatrics emergency unit for children in life-threatening situations; the use of self-injectors of adrenaline in children with serious allergies and risks of anaphylactic reactions; administration of mesenchymal stem cells by means of an animal model with established brain damage; new mediators of inflammation in serious acute bronchiolitis; in addition to continuing the projects started in 2014: an online paediatrics ICU and a simulation centre.

## “Running is an escape valve”

Running, for Juan Carlos Inglés Morales, of the FCC Medio Ambiente team, is an escape valve that helps to overcome day-to-day difficulties. For him, regardless of the level, the efforts invested are returned in an immediate and positive manner and that is the reason why people get hooked on running.

“I encourage everyone to run. It doesn’t have to be everyday, and training does not have to leave you breathless. Let yourself be guided by your own body and in just a few sessions, you will start to notice the benefits of running”, he said.



# 12 months, 12 causes for one objective: road safety

The campaign carried out by the Levante II and Aragón-La Rioja branch offices of FCC Medio Ambiente during 2015, covering three themes in the last quarter – 0 Alcohol and Drugs, Distance and Safety, and Measures to take in the event of an Accident – has ended.

“Twelve months, twelve causes, and one objective 2015” was an annual campaign with different themes every month. It was launched to create awareness on issues involving health, road safety, and sustainable mobility.

The focus during the campaign was to encourage a critical stance in relation to non-compliance with road safety regulations and work was carried out convinced that it was necessary to reduce the number of traffic accidents in mission and in driving to and from work.

The campaign was aimed at employees, users with private and/or company cars and, specifically, to the group of professional drivers.

## 12 topics discussed

- Harsh weather
- Use of the cell phone
- 0 Alcohol and Drugs
- Trucks and vans
- Bicycles and motorcycles
- Speed control
- Distractions
- Safety belt.
- On the road and children's' retention systems
- Safety distance
- Accidents and breakdowns

## Actions implemented

- Periodical distribution of information (posters, leaflets, etc.) in high-traffic areas (dressing rooms, dining rooms, etc.) at all work centres.
- Talks by middle-management before the start of the working day on the selected topics.
- Monitoring in the Safety and Health Committee meetings and other meetings with contractors at each work centre.
- Publications in the Road Safety portal.



See PDF



See PDF



See PDF

# Healthy Christmas

For the second consecutive year, we launched the Healthy Christmas campaign, with recommendations and ideas for spending the holidays and advise that we can apply throughout the year since they are practices and habits that contribute to our health and well being.

We compiled the ideas proposed by our colleagues last year and the staff participated again in this campaign, sharing healthy and enjoyable practices and ideas.



## Enjoy meals with light and healthy products in good company

- Choose healthy dishes, cut back the use of salt, limit the purchase of industrial sweets and eat home-made desserts, fruit and natural dry fruits.
- Dose what you eat, don't gorge and don't make a full meal out of the appetizers.
- Keep digestive infusions at hand for enjoying a good conversation.
- Don't extend the talk at the dinner table and suggest to the other diners to go out for a walk.
- Alternate heavy lunches and dinners with other light meals that help to clean your organism.



See PDF



See PDF

## Sharing life, giving the gift of health and well-being

- Give prevention and health.
- Give smiles.
- Give something that you made yourself.
- Participate in solidarity campaigns.
- "Give what you like, ask for what you need".
- Bring out the Christmas spirit in your surroundings and greet your colleagues, surprise them!
- Create your own toys. Have fun learning and recycling. There are websites with tutorials.

## Be active and enjoy the good atmosphere outdoors

- Abandon your routine and enjoy sports, strolling or playing in the street. Dance, move, much better if you are accompanied by your family or friends.
- For your mental health, be in good humour and smile.
- Visit museums and exhibits.
- Spend time on yourself.
- Don't abandon your good habits.
- Enjoy and take advantage of the magic quietness of the streets during the early morning hours.

## Five years without accidents at the Poniente Almeriense Joint Venture

Mutua Asepeyo rewards the joint venture in charge of managing the Adra, Balerna, Dalías, and El Ejido wastewater treatment plants, participated mainly by FCC Aqualia, for its low accident rate, recording zero accidents since the year 2010.

The award ceremony was presided by José Joaquín Martínez López, director of the Occupational Hazard Prevention Centre of the Junta de Andalucía (Andalusian regional government) in Almeria, by Lidia León Delgado, head of the Provincial Work Inspection, and by Armando Díaz Rueda, director of the Asepeyo Service Centre in Almeria. They gave the diploma for the prize to the head of the department at the joint venture, Carlos Pérez Arribas.

The “0 Accidents” achievement over the past five years is the result of the work and dedication of FCC Aqualia and the

commitment and work of the employees in issues relating to prevention, safety and health. FCC Aqualia is committed to and invests in training and equipment. Employees comply with the recommendations when performing their normal tasks at the installations that require specific work protocols to ensure a high level of safety and also use the equipment correctly and apply the appropriate method.

Thanks to the training provided and the awareness of the employees plus the technical investments to minimise risks, it has been possible to work without having to regret any accidents at work: 5 years, more than 1,800 days, 0 accidents.



## FCC Medio Ambiente, an example of good practices in “Management of Psycho-social Risk at Work”

FCC Group’s environmental services subsidiary, participated in the European Week for Safety and Health at Work Week as a company that is an example in good practices in “Management of Psycho-social Risk at Work.”

FCC Medio Ambiente participated in the event through the seminar organized by Instituto Nacional de Seguridad e Higiene en el Trabajo (National Institute of Safety and Health at Work) entitled “How to approach prevention of psycho-social risks: awareness, participation and good practices”.

Within this framework, several companies presented their programs and good practices experiences that have enabled them to handle this issue successfully and which could serve as a model for other companies.

The importance of managing psycho-social risks correctly is to prevent the positive negative effects that these could have on the worker and his work surroundings, as well as on the company, which negative impacts could result in the overall deficient performance of



the company, greater absenteeism, and a higher rate of accidents and injuries.

The related sick-leave periods tend to be longer than those stemming from other causes and the possible costs for the company and for society are significant.

In compliance with its legal obligations, FCC Medio Ambiente has implemented a plan to

prevent and minimise psycho-social risks and to create a healthy psycho-social environment. All of this leads to the successful management of the company and on maintaining the health and motivation among its workers.

## Training activities

# D+I: changing the order, we lead the future

## Disability + Inclusion: reflections

Fundación Prevent organized at the FCC headquarters in Las Tablas the training activity entitled: "D+I: changing the order, we lead the future. Disability + Inclusion: Reflections". The topic addressed managing disability from a social and corporate perspective and its impact on the company's processes, procedures, and decision-making processes.

The activity covered addressed the issue of managing disability based on the approach of the Human Resources, Procurement, Communication, Systems, and Prevention of Occupational Hazards (POH) departments in their daily management and counted with the participation of Moises who gave a speech on "how having limitations does not mean having a limited life".

This activity is part of a set of training and informative actions on this issue that will be offered from now on and which are part of the Transversal Training Plan and in keeping with FCC's objective of preparing personnel to enable them to manage, completely, optimally, and efficiently the integration of people with disabilities in the social and work environments.

D+I makes it possible to:

- Take advantage of talent.
- Access new potential clients.
- Innovate and mark a difference.
- Comply with regulations.
- Being a step ahead.



### Observatory for Disability and Job Market in Spain



## "End the Awkward" campaign

A survey was conducted to learn about the attitudes of people without disabilities towards those who do (NGO Scope).

67% of Britons feel awkward when interacting with people with disabilities; they have a bad time and try to avoid any contact with them.

48% have never started a conversation with someone with disabilities.

66% have never invited someone with disabilities to a social event. Only 16% have invited them to their homes.

Only 5% of people without a disability have had a date with someone who does.



# Promoting health at work: action strategies

The 4th National Congress on the Prevention of Occupational Hazards took place on 12 and 13 November at the University of Zaragoza. FCC, was represented by the head of the Medical Department of the Aragón-La Rioja branch, Dr. David Blasco Blanco, who described the strategies for promoting health at work that have been developed by the Company and at the FCC Medio Ambiente regional branch.

Dr. Blasco discussed the actions and information for promoting health which generate opportunities for improving the life habits of the company's employees an implies an added value in the Company's management and competitiveness which, in addition to being safe, is healthy, improving the quality of life and well-being of personnel and the image and competitiveness of the company.

Since 2013, Medio Ambiente's Aragón and La Rioja Branch Office, with the participation of Human Resources, POH, Production, trade union representatives and employees, has been carrying out campaigns to promo-



te health. Specifically, a campaign is being carried out on cardiovascular prevention that was launched in 2014 and is expected to be completed by 2019. The campaign includes actions for controlling blood pressure, quitting smoking, and programs to promote physical activities.

The Aragón branch office of Medio Ambiente was recently awarded the AENOR Healthy Company certificate, which is contributing to increasing the safety, health and well-being of workers, reducing absenteeism and increasing motivation and productivity.



According to the World Health Organization (WHO), the right changes in lifestyles could prevent more than three-fourths of cardiovascular mortality rates



## FCC's international management of occupational hazard prevention at Preveexpo 2015



PREVEXPO 2015 is the biennial congress organized by the Junta de Andalucía (Andalusian Regional Government) and social and economic agents to highlight and share contents related to Prevention, Safety and Health.

In this 12th edition, the main issues discussed were the reform of the regulatory framework, training and specialisation, reporting occupational diseases and the

management and evaluation and chemical agents, and the technical profile in the mining industry Juan Carlos Sáez de Rus, FCC's Group director of Safety, Health and Well-being, represented the Company and shared its international experience in managing prevention, safety and health.

Besides describing FCC's international experience, Juan Carlos discussed the Plan of Action that the company implements when it works abroad.

It is essential in all internationalisation processes to know the legal framework of the country and the related official organizations; technical standards; the disciplinary regime, and even the definition of an accident at work.

It is also necessary to know the social and cultural reality of the country or region and, particularly, the country's special economic (boom or crisis) or social political circumstances (armed conflicts, changes in government, etc.).

In addition, it is necessary to anticipate the impact of our management in language or geographical issues, climate (extreme temperatures, sand storms, monsoon rain, etc.) and even matters affecting the environment and health: pollution, diseases, and any other factor that might affect the safety and health of our personnel and the communities where we conduct our activities.

Internationalisation finally means managing diversity in relation to POH, Safety and Health, and learning, adapting, and contributing the best standards to stakeholders and for all of our activities.

# Training plays a key role in safety and health management

The employees of FCC's Central Services at the Federico Salmón, Las Tablas, and Balmes headquarters have been asked to take a course on Risks and Preventive Measures at offices with the purpose of improving knowledge and understanding the risks inherent in office activities and the use of Data Visualisation Screens (DVS) as well as learning about the preventive measures generally implemented to minimise or prevent these risks.

Managed by the prevention area of Central Services, the Safety, Health and Well-being, and the Training Departments, the e-learning mode training including contents on:

- Los General risks in offices and basic preventive measures to eliminate or control such risks.
- Examples on the correct posture in front of a data visualisation screen.
- Basic safety and health recommendations: comprehensive health at offices and stretching and relaxing exercises.
- Basic road safety notions.
- Basic safety notions on fires and first aid.

The activity is part of the Transversal Training Plan that is provided to all Company personnel.

Employees of the main departments and areas of Central Services and the Business Division also received specific classroom training on the legal implications of occupational hazard prevention, which aims to:

- Know the most relevant action, coordination, and operation related aspects in the event of any accident or of a labour inspection conducted at the Company.

- Create awareness on the multiple consequences and liabilities stemming from an accident at work.
- And share action-related practical operational criteria.

Organized by the General Organization Corporate Department, the training session counted with the participation and experience of the Corporate Human Resources, Labour Litigation, and Safety and Health Departments, in addition to the legal counsel. These departments discussed certain issues, including, the general framework of responsibilities for the prevention of occupational hazards and the rules of conduct; administrative responsibilities, and the service surcharge; civil and penal responsibility; management of accidents and the actions of the Labour Inspection, and the responsibilities of the various players involved in prevention.

Other training activities, aimed at the medical services of FCC and the managers of Medio Ambiente regional branch offices, were carried out regarding the new structure and management of the medical services and self-insurance.

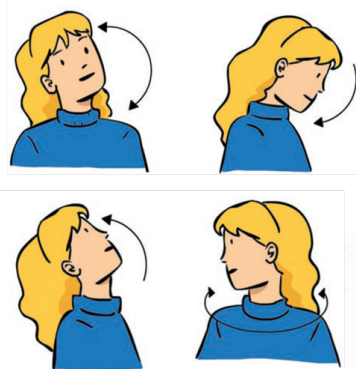

Estiramientos de la zona cervical

## POSICIÓN CORRECTA POSICIÓN INCORRECTA

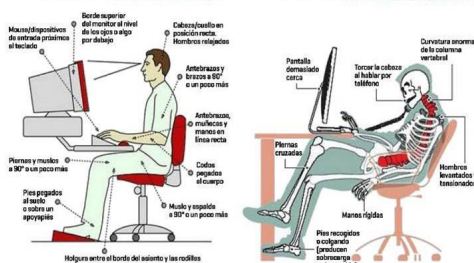

## MANERA CORRECTA

- ✓ Verifique la escalera
- ✓ No se extienda más allá de su alcance
- ✓ Agarre firme
- ✓ Suba mirando de frente a la escalera
- ✓ Zapatos con suela antideslizante
- ✓ Peldaños limpios
- ✓ Aseguré las zapatas
- ✓ Superficie firme



# Meeting on Prevention of Occupational Hazards (POH) at the Environment Division



The annual meeting of FCC Medio Ambiente on Prevention of Occupational Hazards meeting was held on 17 December at the Las Tablas headquarters. POH technicians and coordinators from the 17 branch offices of FCC Medio Ambiente and Central Services, as well as representatives of the Medical Departments, participated in this event. The results of absenteeism and accidents at work during 2015 and the trend in the related direct costs were described in the meeting. Also, the most serious accidents were discussed as well as the related corrective and preventive measures.

In accordance with FCC Medio Ambiente's Strategic Plan for Road Safety 2015-2018, the rate of road accidents was analysed and the Levante II and Aragón-La Rioja branch offices of Medio Ambiente described their experience with the "Twelve months, twelve causes, one objective" campaign.

As to good practices and health, the medical services of the Andalucía II branch described the "Handle stress" campaign and the Canary Islands branch talked about the results of the "Motivation Campaign".

A presentation was made on the work carried out by the Environment Division on the Preventive Resource and the common criteria to be taken into account such as the appointment and training of the worker and his main functions. The results of the "Ergonomic Study of the Worker who performs manual street sweeping" work were also discussed. This study served as the basis for the collectible "Ergofichas" which indicate in a clear and comprehensive manner, the aspects that workers should take into account at their jobs in order to prevent accidents.

The results of the internal and external audits were also discussed at the meeting, explaining the aspects that should be stressed to achieve constant improvement. The medical services also participated and described the organizational changes and those relating to

the new regulations in relation to their impact on the processing of sick leave forms for common illnesses.

The FCC Safety, Health and Well-being Department described the main lines of action for the coming years, focusing mainly on the management of diversity and the healthy company concept. Finally, the Castile-León branch office described its experience in managing the company FCC Equal, S.L. which has as its main activity the provision of cleaning services and whose objective is to integrate people with disabilities in the job market.

# 20th anniversary of the Prevention Law 31/1995

The 8th of November marked the 20th anniversary of Ley de Prevención de Riesgos Laborales 31/1995 (Act on the Prevention of Occupational Hazard 31/ 1995) the aim of which, from its inception, was to ensure the safety and health of workers. This law has served as the basis, framework, and reference for the development of regulations, royal decrees, and laws on the prevention of risks which have dealt in greater detail with various technical and legal aspects.

The enactment of the law implied evolving from a reactive approach (repairing the damage after it had occurred) to a preventive one, with an increasing trend towards safeguarding well-being at work from a holistic management perspective which addresses not only physical hazards, but also those relating to our mental and overall health.

In its essence, the Law details the company's responsibility of protecting the safety and health of workers mainly by means of three essential preventive management activities: the occupational hazard prevention plan; the assessment of risks; and the planning of preventive measures.

FCC has carried out these activities since the law was enacted by being the first, at that time, to create the first management systems for occupational hazards in 1997 and setting up the first prevention shared services in the same year.

Act 31/1995 has been amended on several occasions over the years, particularly as regards the main and general responsibilities of the businessman and the concept of integrating the preventive activity in the company.

Gradually, everyone has become aware of the benefits derived from this integration. Employees are more informed of their rights and obligations in relation to safety at work, recognising the advantages

in terms of production and of the results such as the reduced rate of accidents, related cost savings, less sanctions, and the promotion of the preventive culture.



# Interview

## Arantxa Lobo, head of equality at FCC Industrial e Infraestructuras Energéticas

FFCC Industrial e Infraestructuras Energéticas (FCC IIE) has been awarded the “Equality in the Company” seal in recognition of its equal treatment and opportunities policies. What work is carried out by FCC IIE in this field?

The criteria that are valued the most in awarding the seal is the incorporation of efficient measures that ensure equal opportunities as a core principle of the company and the consideration of women’s talent as a source of strength in the work teams.

For FCC IIE, communication and awareness are essential for socialising the value of equality and for promoting the attraction and retention of female talent. Equality awareness means becoming aware and building new knowledge that generates relationships among the men and women in the workforce based on equality.

FCC IIE has implemented an Equality Plan that backs, supports and promotes the management of equality in the Company.

**What measures contemplated in the FCC IIE Equality Plan would you highlight?**

FCC IIE Equality Plan contemplates several measures of interest to all personnel. These include facilitating work-life balance, equal opportunities for training, promotion, and a protocol on the issue of harassment at work.

The Plan also contains measures to promote the incorporation of female workers in jobs of responsibility, for example, training, such as the course organised by the Industrial Organization School (EOI, Spanish acronym) for women with pre-management potential.

The plan was disseminated among the staff, distributing leaflets on equal opportunities and harassment prevention.

**Based on your own experience following the signature of the 1st FCC IIE Equality Plan in 2012: what aspects do you consider the most important to ensure that it is implemented satisfactorily?**

To ensure the proper functioning of the Equality Plan, it is necessary to define and establish control mechanisms that enable self-criticism and reflection on the scope of its implementation. Throughout the entire preparation of the Plan, it is necessary to count with the participation of the entire company: Management, Human Resources, and Trade Union Representation, and also with the Monitoring and Assessment Committee.

The Company must also incorporate the equality value in its day-to-day business, both in its organizational structure, as well as in all personnel and business processes. It must also socialise this value among the



entire workforce (management, middle-management, administrative and technical staff, etc.).

**What is the impact at the corporate level of the measures implemented, such as work-life balance and joint responsibility?**

In my opinion, the great step that has to be taken to achieve equality is precisely work-life balance and joint responsibility. Although society is certainly evolving towards an equal distribution of tasks, for most women, their main role has to do with family roles and those of a domestic nature.

Despite the measures on flexibility that exist and are available for women and men, the female workers are the ones that take advantage of these measures more frequently, opting to reduce their working day, for example, with the related consequences in terms of salary and future pensions as well as their professional growth.

In order to advance on this issue, the FCC IIE Equality Plan contemplates measures to ensure that the work-life balance rights will not lead to any type of discrimination in relation to training, promotion, salary or any of the other issues contemplated in the Plan.



**¡muévete!**  
**por**  
**tu salud**

**Health**

# Acute gastroenteritis

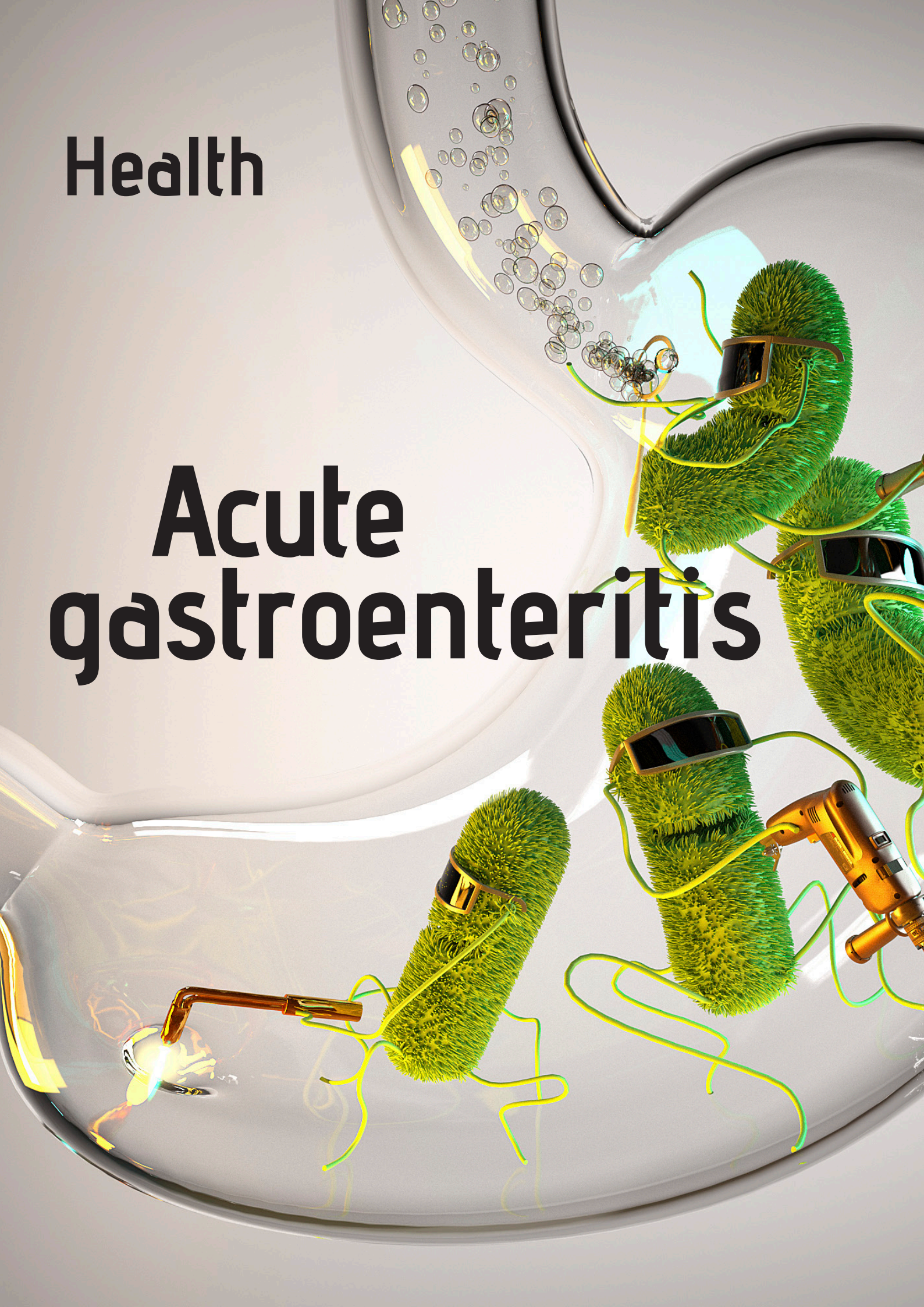



By: Doctor Román Rodríguez Barrigüete,  
Medical Department, Madrid

Gastroenteritis refers to several disorders produced by the inflammation of the gastric and intestinal mucus, the main symptom of which is diarrhea. Diarrhea is considered acute when it does not last for more than two weeks; persistent when it lasts from two to four weeks; and chronic if it lasts for more than four weeks.

It is very frequent and it can be anticipated that nearly 100% of the population will suffer from some form of gastroenteritis during their lives.

### Causes of acute gastroenteritis

Acute gastroenteritis (AGE) can be due to several factors, although in more than 90% of cases, it is due to infection (bacterial or viral).

- AGE can be caused by bacteria in water or in other contaminated food. The infection is passed on from one person to another or by an animal, usually orally (touching your mouth with your hands after being in contact with a possible source of infection).
- Viruses could also provoke watery diarrhea. In fact, in temperate climate regions, viruses are mainly responsible in the winter months for the spread of diarrhea sufficiently serious on some occasions, requiring the hospitalisation of children under 4 and the elderly, in particular, because of dehydration. This could be the case in all types of AGE.

Other less frequent causes:

- Parasites, usually because of drinking contaminated water.
- Acute diarrhea that is not caused by infections is usually due to the ingestion of toxic substances, lactose intolerance, ingestion of heavy metals, or due to the side effects of some drugs (antibiotics).

### Symptoms

The symptoms of diarrhea appear from the start or, generally, a few hours after vomiting has subsided and, in many cases, both coincide. It should be watery or gooey, yellowish or light brown, but it should not contain blood, clots, or pus, or thick mucus. If this is the case, consult your physician urgently, particularly if there you have more than 38° C fever and/or, if you have travelled to a tropical country. Colic pain is normal, provided it is not too intense or lasting, and the abdomen does not become hard (in table). If the stool is as black as petroleum, it is necessary to go to the hospital urgently since this indicates bleeding at some point in the digestive system and this could be extremely serious. Other possible symptoms are pain in the muscles and joints, generally associated with a vi-

rus infection, and drowsiness, consternation, and tiredness when the signs of dehydration appear.

### Treatment

In principle, it is always recommended that you check with your physician who will make the precise diagnosis on the type of gastroenteritis affecting you and, based on this, your physician will be responsible for the specific treatment (antibiotics, etc.).

¿Qué medidas generales podemos aplicar?

- The first one would be the right diet. It is always recommended that if possible, you should abstain from eating solid food during the first 24 hours. The contrary is true with regards to liquids, which should be drunk abundantly (water, isotonic beverages...) and are essential to prevent dehydration. Afterwards, a soft diet consisting of vegetable broths, fish, rice, boiled ham, is recommended. Then, bit by bit, introduce other foods, starting with the most digestible (broiled fish and meat, omelettes, etc.) until we can eat the ones that are more indigestible (legumes, cold meats, fat, etc.). Dairy products should be the last to be introduced in the diet when the patient no longer has any symptoms, and always depending on clinical evolution.
- You should not self-medicate with drugs such as Loperamide (Fortasec) without first checking with your doctor. You must bear in mind that these drugs are contraindicated in bacterial gastroenteritis since they inhibit the peristaltic movements of the intestines and the evacuation of infected faeces. It should be also noted that in these cases, diarrhea helps evacuate the infected gastric juices, preventing that they accumulate in the intestine and make the infection last longer or cause other types of complications (spread of the infection).
- Diet is important. Besides gradually incorporating different types of food, avoiding dairy products for a few days is recommended the irritation of the intestinal mucous provokes a temporary intolerance to lactose. This applies mostly to milk and, to a lesser extent, yoghurt and cheeses since these, in their fermentation stage, contain 30% less lactose, especially in the case of yoghurt. In the case of cheese, those that are the most cured contain less lactose.

## Matinsa develops an intelligent lighting system for tunnels

Matinsa, the FCC Group company engaged in infrastructure maintenance, is working on the Dánae R+D+i project, an intelligent lighting system for tunnels, within the framework of a project funded by the Centre for Industrial Technological Development (CDTI, Spanish acronym). CDTI is a public entity attached to the Ministry of Economy and Competitiveness which promotes innovation and the technological development of Spanish companies.

This system is able to automatically optimise current lighting systems in tunnels. Following the necessary preliminary studies, the system will function in an “intelligent” manner, controlling lightning within the tunnel according to the outdoor light conditions and weather, also taking into consideration traffic density. According to the viability studies carried out, it will be possible to reduce consumption between 15 and 20% without the need to replace the current installations.

The system also features the possibility of including up to five light metres within the tunnel to verify that the light levels comply with regulations and studies thereby easily detecting any incidence and possible failures in the installation.

According to O.C. 36/2015 “Volume II: Recommendations for lighting in tunnels” on the criteria to apply to outdoor roads and tunnels: “...lighting installations in tunnels should be integrated in centralised tunnel management programs and, if this does not exist since it refers to a tunnel that does not require it, it should be controlled by means of automated systems”.

Based on the previous recommendations, the main advantages of using the Dánae system are as follows:

- Ability to capture and transmit the electrical characteristics of the components of the installation, making it possible to know these characteristics in real time.
- Makes it possible to turn the points of light on or off according to a predefined management strategy.

- Transmits information in the event of unauthorised entry in the installations.
- The utilisation of this system reduces costs and improves the maintenance work at the facilities, minimising the periods in which the lights are turned off when this should not be the case.
- Records the variations in the voltage of the electricity supply, detecting over-voltage, thereby being able to take the appropriate measures.
- The communication protocols are open and can be integrated in other management systems or in SCADA.
- Improves energy efficiency in existing installations without having to make any changes except for installing the system.



- All energy variables are detected and stored in a database thereby enabling the subsequent use of these variables to constantly improve the efficiency of the installation.
- In the event of failure of the Dánae system, lighting would be controlled again as pre-established in the SCADA system since the entire installation is parallel to the one installed initially.

Since Dánae is a universal system, it is compatible with any lighting installation in tunnels. It is designed in such a way that it can control any types of lighting systems, including LED. Likewise, data on the lighting strategy applied and measurement variables are stored and can be communicated to SCADA, the software that makes it possible to control and su-

pervise industrial processes at a distance, since the protocol used is open and can be integrated easily.

This new system includes a web application that enables the client to check data, generate charts, and constantly improve the efficiency of the installation. The application can be accessed with a username and password from any point with internet access. This tool will be very useful for the manager of the energy in the tunnel when making decisions on the lighting strategy to be implemented.

## Leader in the Spanish market

Mantenimiento de Infraestructuras, S.A. (Matinsa), an FCC Group company founded in 1992, is the leader in the Spanish infrastructure conservation market. Its activities include all areas related to the conservation of major infrastructures (roads, railways, water works, and forest projects).

# The first ELAN® technology wastewater treatment system is already functioning in Spain

“  
Patented by FCC Aqualia,  
the ELAN® technology  
significantly reduces energy  
consumption and sludge  
wastewater treatment  
processes  
”

After several years of functioning at a pilot scale in the Vigo and Guillarei (Pontevedra) wastewater treatment plants, the construction of the ELAN® system in the latter was completed successfully. The delivery of the work was witnessed by Juan Pablo Barrio (department manager at Augas de Galicia) representing the Administration; Rufino Rodríguez (manager of Consorcio de Augas do Louro); and, Enrique Cabaleiro (the ma-

yor of Tui). FCC Aqualia was represented by Roberto Fernández (manager of Depuración de Galicia); Ramiro Gutiérrez (head of the Guillarei WWTP); David Soneira (head of Production at the Pontevedra and A Coruña branch offices); Nicolás Morales (member of the Innovation department; and, Miguel Payá (Project manager).

Work is currently being carried out on ELAN® system by the Innovation Department team, the employees of the Guillarei WWTP, and by the Production team in Galicia.

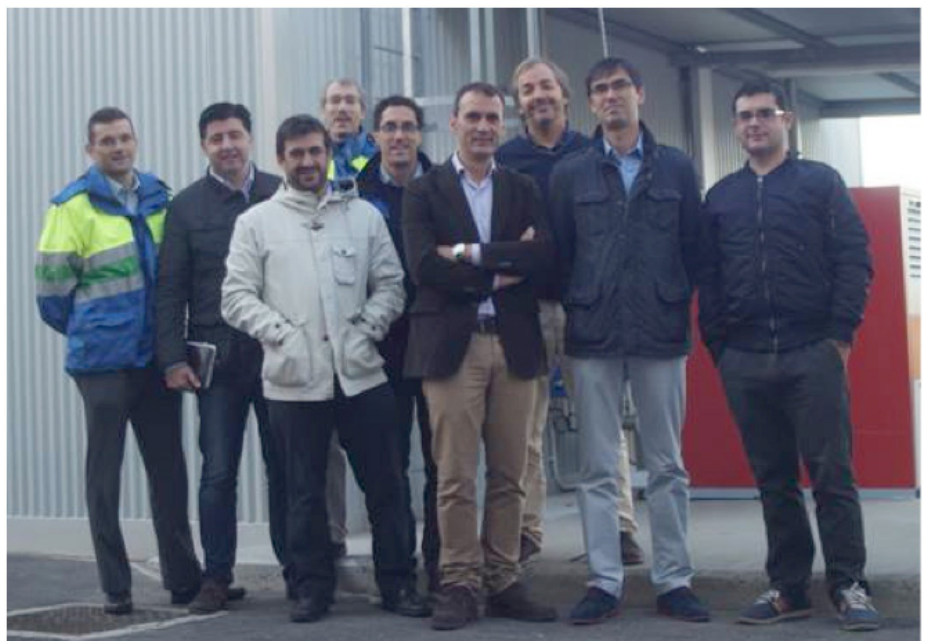

In the photo, from left to right: Miguel Payá; Pablo Fernández, engineer at Augas de Galicia; Juan Pablo Barrio; Roberto Fernández; Ramiro Gutiérrez; Enrique Cabaleiro; David Soneira; Rufino Rodríguez; and Nicolás Morales.



Outdoor view of the building housing the underground homogenising tank and the two ELAN® reactors which are part of the project.

The development of this technology reaches its last phase thanks to the successful collaboration of the company and the University of Santiago de Compostela (USC) which since 2000 have been investigating the anammox technology which is at the core of the ELAN®, system. Since 2009, the Company has worked jointly with the University of Vigo on the automation, control, and monitoring system for this technology.

The Administration has also wagered on the ELAN® technology. Augas de Galicia has sponsored the project executed at the Guillarei treatment plant. This commitment is evident as shown by the support of the Xunta (regional governing body) for the first pilot projects in Vigo and by CDTI which has co-funded the development phase in Guillarei.

After two months of operations, the system has reached 100% of its capacity for partial nitrification and it is anticipated that in six months the system will reach a treatment

capacity of 0.6 kg N/(m<sup>3</sup> d), the unit's design value. After this success at the industrial scale, FCC Aqualia has already secured another contract from Frisco, a company in Porriño (Pontevedra). Future implementations of this technology are planned for Barcelona and several proposals have already been submitted in Spain and abroad.



**Funded originally by the Xunta de Galicia and CDTI, the project is sponsored by Augas de Galicia and by Consorcio del Louro, in addition to the collaboration of the Universities of Santiago de Compostela and Vigo**





The Place

# Callao Port, Perú

## Enlargement of one of the largest ports in the Pacific.

Callao Port, in the easternmost part of Lima, is considered one of the most important ones in Peru and the largest in South America's Pacific coast.

APM Terminal hired the FCC and JJC consortium to execute the project for the enlargement of the port. The north pier had a capacity for 500,000 containers which will be enlarged to accommodate 1,000,000 containers per year. Thanks to this project, it was possible to double the number of operations at the port.

The project contemplates the construction of Phases I and II of the port: the remodeling of Pier 11 (for grains) and the north part of Pier 5, which will enable the arrival of larger ships: Gran Post Panamax.

Pier 5 and another 11 existing piers plus 18 buildings within the port were demolished. Pier 11 and Pier 5 are 280 and 560 metres long, respectively. Pier 5 is used for handling containers and mineral loads while Pier 11 provides port services for food imports and features cement silos for storage.



“

The traffic capacity of the port will be one million containers per year

”

The upgrading work also includes the construction of an administration building (five floors plus a rooftop terrace), a public office building (two floors), a maintenance workshop, and other minor projects.

One of the first deliveries required by the client was completed in Pier 5 since the client had purchased cranes to lift containers in China and it was necessary for part of the pier to be completed in order to install this equipment. FCC fulfilled its commitment and, when the cargo arrived, the new platform was ready for its installation.

The port project will upgrade the infrastructures to adapt them to the current demands

of the cargo transport system and to provide it with improved performance equipment in line with the different types of cargo handled at the port. Work on the 206 million dollar project began in 2013 and a substantial completion of the project was achieved on 18 December when it obtained the “Sectional Completion Milestone 5” taking over certificate.

## Progress achieved in the project



**Pier 11.** 280 metres long, completed. Delivered as part of milestone 4 on 14 February 2015. Taken over on 24 May and started operations on the 26th of the same month.



**Pier 5.** First milestone completed on 28 August 2014 with the first 186 metres of Pier 5 to make it possible for the client (APMTC) to download and the STS Super Post Panamax cranes with a reach of 68 metres, equivalent to 23 lines of containers, in order to be able to receive the largest ships in the world, and transfer 18,000 twenty feet containers. On 15 March 2015, another important milestone was reached by completing up to 360 ml. Of the pier which made it possible to continue with the pier's operations on the arrival of large ships. The full 560 ml. were finally completed in July 2015.

### Buildings

- Administrative and public building was completed and delivered to the client on 28 April 2015.
- Other buildings: (Workshop, Amenity, already completed).

### Pavement

The new access areas and enlargement of the container park are already completed after paving 157,000 m<sup>2</sup>.



## Training in Occupational Safety and Health

FCC developed a complete training and information program, the most important pillar of a management system. The program aims to create awareness and responsibility in applying the management system to ensure the competency of personnel.

We are in charge of training all personnel. This training includes handling tools, working at heights, electrical works and work in confined spaces.



Data: 102,000 man hours in training from the start of the project.

# Interviews

## Rafael García Arroita, head of the Maritime Project



From left to right: Rafael García, Fernando Herrera and Helios García.

### How did you participate in the project?

I joined the project as the head of production to take charge of the dredging activity, driving of piles, fillings, and pillars. Since August 2014, I have been the project manager.

### What would you highlight about the project?

Undoubtedly, it was the pioneering use of a cofferdam-type waterproof retaining wall so as to be able to work underwater cutting and welding and preparing the pillars over which the prefabricated beams are subsequently placed.

This work had never been performed in this type of project and it was thanks to the exclusive intervention of FCC (design, manufacturing and execution from scratch) that made it possible to implement this solution, complicated mainly because of safety concerns.

Also the pile-driving operations had to overcome the difficulties of terrain as complicated and unpredictable as the gravel in Lima. It should also be mentioned that the project is being executed in a port and piers in operations which means that any task is complicated due to sea and land traffic. The

coordination with other APMT (operations) areas is constant and requires enormous efforts since the project is a full-time job for both parties.

### What has this experience meant for you?

Professionally, I had to adapt to a work method in a country where, despite speaking the same language, is very different from Europe in terms of pace and magnitudes. You are also more exposed than in Spain since the problems have to be solved mainly by the personnel at the worksite.

Personally, I am very proud of completing two of the milestones and to see that, despite the problems encountered, we were able to achieve the objectives that, looking from outside, seemed impossible. It was also hard to see how many colleagues were affected by the demands of work abroad and in such a complicated project.

Lastly, this is a FIDIC (International Federation of Consulting Engineers) Red project, one of the most frequently used construction contract model worldwide, drafted in English and both the client as well as Supervision involves personnel from various countries such as England, Holland, Malaysia, etc. This has enabled me to learn different ways of working and I have found this to be very enriching.

### What do you think marks the difference between FCC and the competition?

The know-how and the team of people who contribute the Company's vision of profes-

sionalism and safety. The involvement of the personnel in the project is also a differentiating factor.

### What is it like to live in Lima? What do you like and what don't you like about it?

The city spreads over a large area, but we live our lives in two neighbourhoods and, therefore, at the end, it seems very small. I don't like the traffic jams and the few leisure activities to be able to disconnect, also the fact that you have to take a plane and travel far if you want to leave Lima. What I like the most is the food and the habit of running. The problem is that working from Monday to Saturday, there is little time left to disconnect from the project.

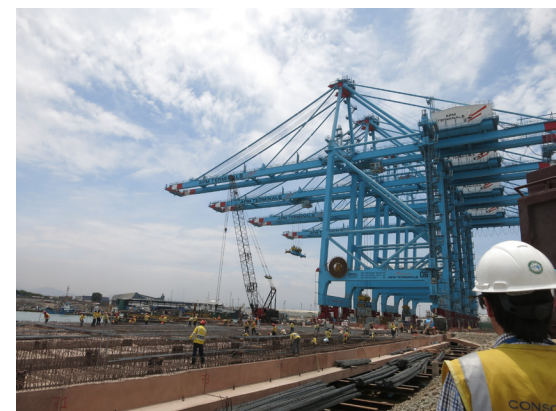

# Helios García Asensio,

## Safety, Health and Environment manager

### How many people are working at the project?

In April 2014, we had a peak at 1,660 workers and the monthly average number is about 1,200 workers.

### Can you describe the safety and health plan?

The Safety Plan for this project addressed the client's strict requirements and we had to develop an Integrated Safety and Health at Work Management System and implement an entire health unit to provide the project with the means to be self-sufficient in case of need, including assistance, medical staff, an ambulance, etc.

### In terms of the environment, what steps did you take?

We developed an Environment Plan as an in-house management system.

### How do you work? What is it like day-to-day?

We cannot forget where we are. It is an area that the client assigned to us to execute the project in a port in operations and in an interesting part of the country where we are responsible for everything, including access control. We had to provide the project with the necessary mechanisms to ensure that the work was carried out correctly, in liberated areas, interferences with operating areas of the client. We implemented an operational control in line with these requirements.

### Of what actions are you proud?

Participating in an innovative project that allows us, through the mechanisms that we established, to execute the project safely, increase the level of training and the commitment of the personnel at the project through our incentive programs and the end-of-the month awards.

### How long have you been in Lima?

From the start of the project, that is, two and a half years.

### How would you rate your experience?

Positive. The project has enriched me as a professional, has made me grow. It was a challenge at first. The project is technically difficult because of the use of the Cofferdam and this made us demand more of ourselves.

### What does working in this project mean to you?

At the beginning, it was very difficult. We had to convince the client that we were able to execute the project and that the HSE department was capable of meeting the requirements and that working together we would be able to bring the project to a successful conclusion.

# Antonio Carballo, general supervisor of FCC

### What was it like to go abroad to work?

It was not the first time since I worked in Switzerland for 12 years. Nevertheless, the experience in Peru has been different and, overall, it has been a positive experience.

### Have you noticed much difference in the workers/resources at work here in comparison to Spain?

It is more difficult here to be in contact with employees with a high level of specialisation. The ancillary technical resources are

more limited or difficult to obtain on time. Adaptation has been difficult.

The best of these two years at the project: Working together with the project team. Using new work equipment, the Cofferdam, and being able to ensure its positive performance.

The worse of these two years at the project. A family issue: distance. The project requires a large workload and having the family here and not being able to spend much time with them is difficult.



Rafael García and Antonio Carballo, on the left, with another member of the team.

# Antonio Franca, Project Implementation Director APM Terminals



Antonio Franca is the implementation director of the Callao Port Project. He has been working for APM Terminals since 2007, although it was not until 2012 that he joined the project shortly after the work began on the remodelling, enlargement, and upgrading of the Puerto de Callao project being executed by the FCC-JJC consortium.

## Tell us about your work.

As the project manager, I am in charge of supervising the project and its objectives in accordance with the provisions of the Concession Agreement, providing the physical assets to bolster the overall capabilities of Callao Port.

## How did the project come up?

The Port of Callao was built between 1930 and 1060. At that time, it was an impressive infrastructure but 70 years later, it had reached the limit of its useful life.

After bidding for the Concession of the Port of Callao, North Pier in 2011, APM Terminals won the concession for the operations

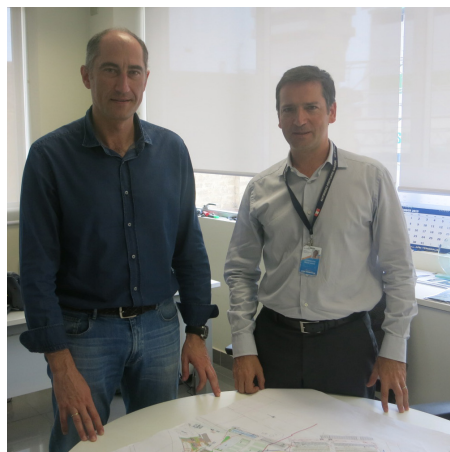

In the image, Fernando Herrera and Antonio Franca.

of the North Terminal for a 30-year period. One of the obligations contemplated in the Concession Agreement was the development and preparation of the port infrastructure for the next 50 years.

The development plan pursuant to the Concession Agreement contemplates the development of five phases in which, the two first phases will be completed in the first quarter of 2016.

In Phase 1, 560 metres of new pier walls were built, new buildings, a new access was built, with 4 STS cranes (downloading at the pier) and 12 cranes, jointly with other equipment. Phase 2 calls for the development of a multi-purpose 278 metre long pier for bulk loads with a transporter system.

## Objectives of the project?

- Improve the level of service by building new pier walls and storage areas and by acquiring state-of-the-art equipment.
- Build an infrastructure that is prepared to handle the expected growth and development of Peru over the next 50 years where the FCC-JJC Consortium is playing an important role.
- Improve the operational processes: we have increase the movement of containers twofold, from 800,000 to 1.5 million tons.
- Build and operate, which implies minimising the interruptions in current operations as well as the construction activities.

## What have been the main challenges?

The main challenge in a project of this nature is the fact that the construction work is being carried out simultaneously as the current operations. This, without any doubt, is a work involving coordination and logistics to ensure that the different tasks are executed on time, minimising the impact on current operations.

## How would you rate, as the client, the work executed by the consortium, specifically by FCC?

The Consortium did a good job and executed the work successfully. The project did not begin as had been expected; we faced some challenges in the mobilisation period. Nevertheless, we can assert that the initial problems were overcome week by week. We recognise the efforts made to complete the project successfully.

Thanks to the good collaboration and coordination, the Consortium was able to minimise the impact on current operations and that is something for which we are very grateful.

FCC contributes experience, technical knowledge, engineering solutions; it is close to and interrelates with the communities, respects people and is committed to local development.

Furthermore, its contribution in Occupational Safety and Health has been very important, reaching excellent safety standards at the project. I believe that FCC has the best team for the project, living up to the expectations, challenges, and requirements.

# Communities

## FCC to recycle Dallas waste for 15 years

“  
The turnover volume  
for the plant is around  
270 million euros  
”

The US city of Dallas has awarded FCC the contract to build and operate a plant to manage all of the recyclable waste in the Texan city for a period of 15 years, which may be extended by a further 10 years. The turnover volume for the plant is around 270 million euros (300 million dollars) over the course of its lifetime.

The area of Dallas-Fort Worth is the fourth largest metropolitan area of the United States with nearly 7 million inhabitants, after New York, Chicago and Los Angeles. This makes it strategically significant for FCC's environment business in the US.

Under the terms of the contract, FCC will have the exclusive right to the material from all recyclable waste containers in the city of Dallas for the period awarded. A total of six companies took part in the tender announced by the Dallas' Sanitation Services Department. FCC came out top in the technical criteria assessed in the tender.

In order to recycle the waste in the Texan city, FCC will build an automatic sorting plant using state-of-the-art technology. This will use the latest sorting and classification techniques, including artificial vision, as well as optical and gravimetric sorting machi-



nes. The new facilities will sort all of the waste collected in the single recycling container into different categories.

The plant will recycle and give thousands of tonnes of paper, cardboard, glass, plastic, metals, etc., produced by the citizens of Dallas, back to the market, thereby returning it to the production cycle.

FCC has extensive experience with similar plants in several countries across the world, with over 50 facilities currently available and similar to the proposal for the Texan city.

Following the recent contract awarded to the Citizen Services Group in Orange County (Florida), the first Municipal Solid Waste (MSW) collection contract given to a Spa-

nish company in the US, and the biosolids management contract in Houston and the end of 2014, this award consolidates FCC's aim to launch their services in North America where they plan to capitalize on their 100+ years' experience in the environmental services sector across the world.

“  
The new facilities will sort all of the waste collected in the single recycling container into different categories  
”

## Key figures

### Processing capacity:

- Up to 120,000 tons/year in single stream processing.
- 25,000 tons/year of commercial waste.

**Term of the contract: 15 years, extendable for another 10.**

### Main recycled items:

- OCC (old corrugated cardboard).
- ONP (old newspaper pulp).
- Glass.
- Plastic containers: PET and PEAD.
- Metal containers.

